



Beta *Action*

2018

**Promotion
Valid until
15/12/2018**

Workshop Equipment



 **Beta**
RSC55

*Configure your
workshop online*

**360°
view**



www.beta-tools.com/RSC55en



[www.youtube.com/
wwwbetatoolscom](http://www.youtube.com/wwwbetatoolscom)



Index



Automotive	52÷76
Beta collection	96
Bits	25
Containers and Assortments	2÷15
Cutting tools	36
Drilling and threading tools	35
General maintenance tools	42÷51
Hammers and chisels	34
Male-end wrenches	23÷24
Measuring tools	37
Pliers	32÷33
Plumbing tools	40÷41
Pneumatic tools	77÷82
Pullers	38÷39
Safety footwear	83÷90
Screwdrivers	26
Sockets	27÷29
Thermoformed trays	16÷19
Torque wrenches	30÷31
Workwear	91÷95
Wrenches	20÷22

An advertisement for the Beta Soft Ware Module System. On the left, there is a stack of colorful toolkits (blue, yellow, green, red) with one open showing various tools like pliers, screwdrivers, and sockets. On the right, a computer monitor displays a software interface with multiple panels, including a large image of a power drill and a smaller image of a person using a keyboard. A white arrow points from the monitor towards the toolkits. In the top left corner, the logo for 'Beta SOFT WARE MODULE SYSTEM' is displayed. The background is a dark blue gradient with the text 'CUSTOMIZE YOUR ASSORTMENTS' in large white letters.

C39 Aluminium AL

Mobile roller cab

- Four castors with steel cores, Ø 125 mm: 2 fixed and 2 steering (one with brake).
- Front centralized safety lock.

Uprights and drawer front made of aluminium alloy
+ STURDINESS + LIGHTWEIGHTNESS



- Pull-out drawer with opening system throughout its length.

Sturdy multi-purpose worktop with tote-trays and holes for accommodating screwdrivers.



Built-in side and rear bottle and paper holders.

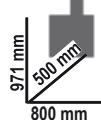

	Ral 2011	Ral 7016	Ral 3000	n° 367mm 588mm	n°		 kg	
C39/6	039000031	039000032	039000033	6	4 70 mm 30 kg		59	
C39/7	039000001	039000002	039000003	7	1 140 mm 35 kg		61	
C39/8	039000041	039000042	039000043	8	1 210 mm 35 kg		64	
					5 70 mm 30 kg			
					1 140 mm 35 kg			
					1 210 mm 35 kg			
					6 70 mm 30 kg			
					2 140 mm 35 kg			

SOFT MODULE SYSTEM



5988 U6/MP

Assortment of 214 tools in soft foam trays

Recommended for use in combination with mobile roller cabs: C24S-C24SL-C33-C39-C28-C59

L 059880530 XL 059880531

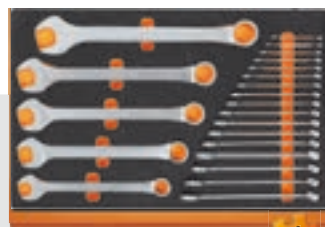

M10 22



M30 31



M210 25



M230 25



M130 13

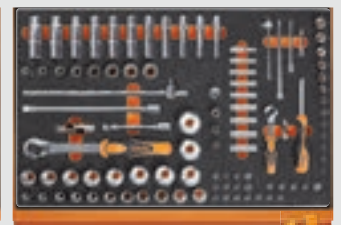

M100 98

For drawer: 588x367 mm assortment only

new item C33

Mobile roller cab

- Four castors with steel cores, Ø 125 mm: 2 fixed and 2 steering (one with brake).
- Front centralized safety lock.

Higher, sturdier, safer!



Convenient "V" groove for working pipes and sections.

Sturdy multi-purpose worktop. Tote-trays and holes for accommodating screwdrivers.



Built-in side bottle and paper holders, adjustable in several position

Corner bumpers throughout height of roller cab, to avoid damaging vehicles in garage.



Pull-out drawer with quick release system made of fibreglass-reinforced nylon, opening throughout length of drawer.



1020 mm
800 mm
810 mm

	Ral 2011	Ral 7016	Ral 3000	n° 367mm 588mm	n° 75mm 150mm 305mm	kg	
C33/6	033000261	033000262	033000263	6	4 75 mm 30 kg 1 150 mm 35 kg 1 305 mm 35 kg	69	
C33/7	033000271	033000272	033000273	7	5 75 mm 30 kg 1 150 mm 35 kg 1 225 mm 35 kg	71	
C33/8	033000281	033000282	033000283	8	6 75 mm 30 kg 2 150 mm 35 kg	73	



5904U/MP

Assortment of 91 tools in soft foam trays

Recommended for use in combination with mobile roller cabs: C24S-C24SL-C33-C39-C28-C59

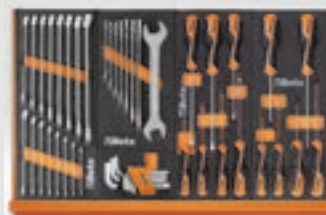

M15 M33 M199 M202



M50 M83



M132 M153 M234 M145

L 059040428 XL 059040429

For drawer: 588x367 mm
assortment only

C24S

Mobile roller cab

- Four castors with steel cores, Ø 125 mm: 2 fixed and 2 steering (one with brake).
- Front centralized safety lock.
- Can accommodate paper roll holder item 2400S-R/PC, to be ordered separately.



Sturdy ABS worktop.



Pull-out drawer with quick release system made of fibreglass-reinforced nylon, opening throughout length of drawer.

Built-in side bottle holder.

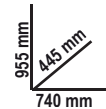

	Ral 2011	Ral 7016	Ral 3000	 n° 367mm 588mm	 n°	 kg	
C24S/6	024002061	024002062	024002063	6	4 70 mm 25 kg 1 140 mm 30 kg 1 280 mm 35 kg	55	
C24S/7	024002071	024002072	024002073	7	5 70 mm 25 kg 1 140 mm 30 kg 1 210 mm 30 kg	58	
C24S/8	024002081	024002082	024002083	8	6 70 mm 25 kg 2 140 mm 30 kg	61	



5904VA/T

Assortment of 102 tools in foam trays

Recommended for use in combination with mobile roller cabs: C24S-C24SL-C33-C39-C28-C59

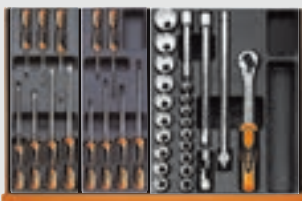

T199 T202

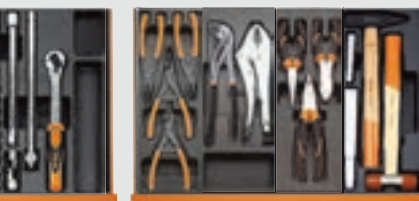

T83 T145 T153 T131 T234



T52 T33 T15 T16



T63 VP5

L 059040410 XL 059040411

assortment only

C24SA-XL/7

Mobile roller cab with anti-tilt system, long model

- Four castors with steel cores, Ø 125 mm: 2 fixed and 2 steering (one with brake).
- Front centralized lock.
- Can accommodate paper roll holder item 2400S-R/PC, to be ordered separately.

ABS worktop, with 6 tote-trays.



Sturdy nylon front, with built-in label holder.

Built-in side bottle holder.



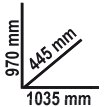
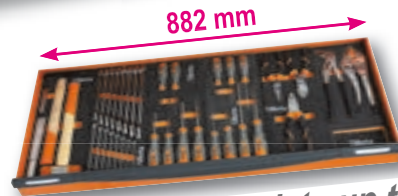

Anti-tilt system



Can accommodate up to 6 thermoformed trays in one drawer

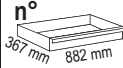

	Ral 2011	Ral 7016	Ral 3000	n° 	n° 	kg	
C24SA-XL/7	024002271	024002272	024002273	7	5 70 mm 30 kg 1 140 mm 35 kg 1 210 mm 35 kg	84	
C24SA-XL/8	024002281	024002282	024002283	8	6 70 mm 30 kg 2 140 mm 35 kg	88	
C24SA-XL/9	024002331	024002332	024002333	9	8 70 mm 30 kg 1 140 mm 35 kg	92	

SOFT MODULE SYSTEM



5988UX/MP

Assortment of 135 tools in soft foam trays for mobile roller cab C24SA-XL



M16 M15 M33 M145 M131

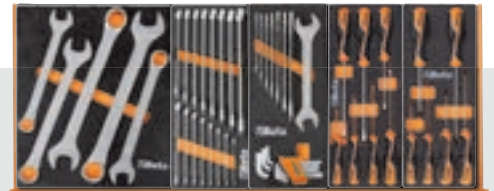

M50 M55 M153 M199 M202



M234 M236 M83 M289 M91

L  059880540 XL  059880541

assortment only



C24SL-CAB

Mobile roller cab with 7 drawers and tool cabinet

- Four castors with steel cores, Ø 125 mm: 2 fixed and 2 steering (one with brake).
- Front centralized lock.

Multi-ply wood worktop with holes for a vice (1599F/100, to be ordered separately).



Side cabinet with vertically adjustable interior top and lockable door.



Built-in paper roll holder. Double rear bottle holder.



024002191 024002192 024002193

n°	n° 367mm 588mm	↓ max
5	70 mm	25 kg
1	140 mm	30 kg
1	210 mm	30 kg

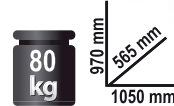

C28

SuperTank trolley with worktop and 10 drawers

- Five side drawers and five front drawers
- Four castors with steel cores, Ø 125 mm: 2 fixed and 2 steering (with brakes)
- 2 centralised safety locks.
- 4 bottle holders: 2 front and 2 rear.
- 6 side tote-trays.
- 135-mm-high storage compartment with plastic-covered base.

Multi-ply wood worktop with holes for a vice (1599F/150, to be ordered separately).



Quick, safe system for opening and closing drawers, with nylon and fibreglass front.



Side compartment with foldaway door with lock.

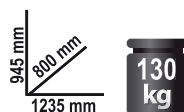

n°	n° 367mm 588mm	↓ max
8	70 mm	25 kg
2	210 mm	30 kg



028000301 028000302 028000303



C59A

Endurance workbench with 1 cab with 6 drawers

- Drawers protected by foamed rubber mats.
- Hard-wearing nylon drawer front.
- Roller cabs can accommodate thermoformed trays.
- Front centralized safety lock.
- Lower object shelf.
- Can be fitted with paper roll holder (2400S-R/PC) and bottle holder (2400S/PF), to be ordered separately.



059000001 059000021 059000041

Worktop made from multi-ply wood with holes for vice item 1599F/125 (to be ordered separately).

Kg
1500

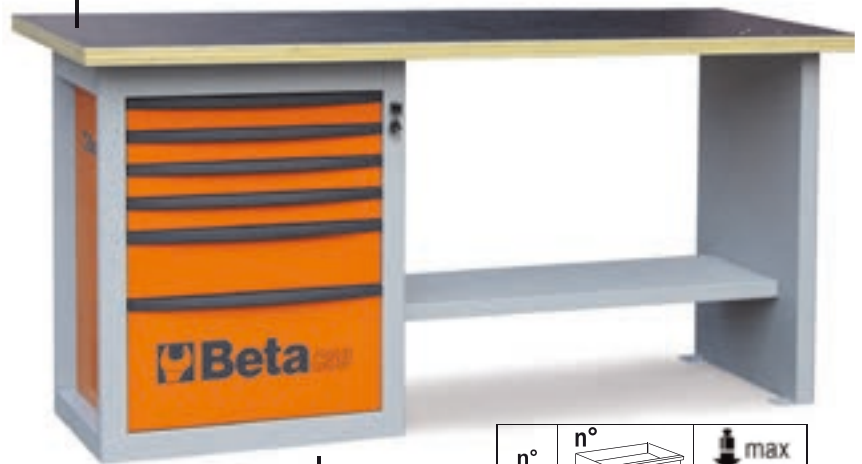

900 mm
700 mm
2000 mm

115 kg

n°	n° 367mm 588mm	↓ max
4	70 mm	25 kg
1	140 mm	30 kg
1	280 mm	35 kg



C56

Workbench

- Worktop made of painted sheet metal with external edge.
- Steel frame with 6 supporting legs.
- Two drawers with lock.
- Can be fixed to floor.



056000201 056000202 056000203

Kg
1200



82 kg

930 mm
640 mm
2000 mm



C51

Trolley

- 3 tops covered in antislip ribbed rubber
- Two fixing options for central worktop
- Four castors Ø 100 mm:
2 fixed and 2 steering (one with brake)

Kg
200



21 kg

900 mm
450 mm
800 mm

051000001 051000002 051000003



CP51

High-grade trolley

- 2 tops covered with rubber mats
- Four high-grade castors Ø 125 mm:
2 fixed and 2 steering (with brakes)

Kg
750



37 kg

900 mm
600 mm
900 mm

051000501 051000502 051000503



C35 *new item*

Industrial tool chest

- With pull-out drawers 600x447 mm
- Front centralized safety lock.



kg
1200



3500/P

Worktop with external edge
717x600 mm



035000502

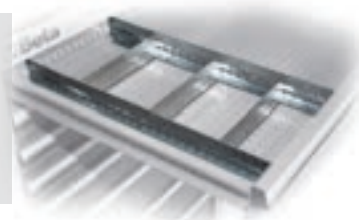

8889C6/7,5

Crossed partitions
for drawer
h 7,5 cm



088890475

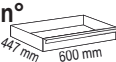

	Ral 7000-7035	n° 	n° 	kg	
C35/6	035000062	6	2 75 mm 70 kg 1 100 mm 70 kg 1 150 mm 70 kg 1 200 mm 70 kg 1 300 mm 70 kg	73	
C35/7	035000072	7	2 75 mm 70 kg 1 100 mm 70 kg 3 150 mm 70 kg 1 200 mm 70 kg	77	
C35/8	035000082	8	4 75 mm 70 kg 1 100 mm 70 kg 2 150 mm 70 kg 1 200 mm 70 kg	80	
C35/9	035000092	9	6 75 mm 70 kg 3 150 mm 70 kg	84	



**SOFT
MODULE
SYSTEM**

new item

5935VI/MB

Assortment of 133 industrial maintenance tools for tool chest C35, in soft foam trays



MB11



MB34

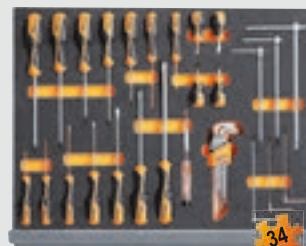

MB44



MB55

L 059350410 XL 059350411

For drawer: 600x447 mm



Beta stainless steel tools
can be autoclave sterilized at 121 °C

Containers



C04TSS/7

Mobile roller cab with seven drawers, made of stainless steel

- Four castors with steel cores, Ø 125 mm: 2 fixed and 2 steering (with brakes);
- Front centralized lock;
- **Frame made entirely of stainless steel**
- **Castors, supports, ball bearings, drawer interiors and guides made of stainless steel**
- Drawer handles made of aluminium

n°	h	max
6	83 mm	25 kg
1	170 mm	30 kg

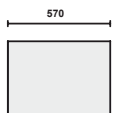

024003077



63 kg



C27S

Folding tool trolley for outdoor jobs, empty

- Folding tool trolley, with folding columns for effortless transport.
- 2 drawers, 588x277 mm, with ball bearing slides, for two-way opening.
- Large lower object compartment, 588x277x220 mm.
- Sheet metal frame.
- 2 fixed castors, Ø 160 mm, and 2 steering castors, Ø 100 mm with brake.
- Thermoplastic worktop with 6 built-in tool trays.
- Centralized lock.
- Can accommodate drawer partitions and MC foam tool trays

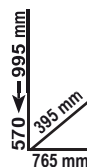

20 kg

n°	h	max
2	70 mm	20 kg

027000201

027000202

027000203



5927VU/M

Assortment of 108 tools in soft foam trays for trolley C27S

059270021

assortment only



3A

MC10

For drawer: 588x277 mm

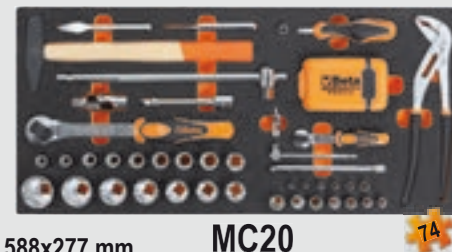

7A

MC20

C41H

Two-module tool trolley

- Sheet metal frame and plastic top, synonymous with remarkable sturdiness and reduced weight.
- 2 detachable modules: 1 upper tool box, 1 module with 2 drawers 95 mm in height, 1 pull-out case made of plastic, 66 mm high, and 1 drawer 295 mm in height.
- Oversized castors (160 mm), built into frame for easy transport - for example, on steps.
- Side centralized lock for closing drawers of lower module.
- Drawers with ball bearing slides and double closing hook.
- Telescopic aluminium handle.
- Small tool holder built into upper tool box.
- Lower drawer with double ball bearing slides



C41H W
RAL 9016

C41H Y
RAL 1023

C41H R
RAL 3000

C41H V
RAL 6024

C41H B
RAL 5002

C41H G
RAL 7016

C41H N
RAL 9005

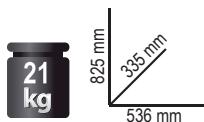

041000002	041000021	041000012	041000008
041000024	041000006	041000010	041000005



C42H

Three-module tool trolley

- Sheet metal frames and plastic tops, synonymous with remarkable sturdiness and reduced weight.
- 3 detachable modules: 1 upper tool box, 1 central tool module and 1 lower tool module with castors.
- Oversized castors (ø 160 mm).

Telescopic handle, can be adjusted in 3 positions



Can be used with 2 modules



Upper tool box with interior object compartment and 3 tote-trays built into cover.



Quick module release system: easy, quick access to all tool compartments.

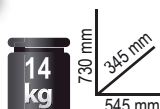

042000002

Containers

C20L

Five-section cantilever tool box, made from sheet metal, empty

021200002



550x200x210 mm

CP17

Tool box, made of stainless steel and plastic, removable tote-tray, empty

021170500



500x200x220 mm

CP15L

Tool boxes, made from plastic empty

- 3 tool trays built into cover with adjustable partitions
- 1 interior tote-tray with adjustable partitions
- Carrying capacity: 30 kg



558x277x270 mm

021150202



CP15



445x240x250 mm

021150201

2080/V12

Organizer tool case with 12 removable tote-trays

300x330x145 mm

020800000



Removable, folding clear tote-trays, for immediate recognition of contents



new item

C14

Tool trolley, made of polypropylene, with 4 drawers, empty

- Injection polypropylene frame for increased shock resistance.
- 4 sturdy rear castors
- Removable top tray
- 3 tote-trays included
- Nameplate
- Can be closed with TSA lock

Tool panel built into lid



Lid-protected front accommodates 4 pull-out drawers (470x255):
 1 drawer 30 mm high
 2 drawers 60 mm high
 1 drawer 90 mm high



Front centralized lock allowing top and front lids to be closed simultaneously.

Two side handles



10 kg

021140000

580x380x455 mm

new item

5914VU/M

Assortment of 109 tools for tool trolley C14, in soft foam tray



MC T1

70



MC T2

29



MC T3

10

* When used in combination with tool trolley C14, remove upper tool panel.

059140109

Containers

2037/TV

new item

Tool trolley, made of polypropylene, with 4 pivoting wheels, empty

- Highly shock resistant. Suitable for tool transportation in aircraft.
- 2 tote-trays included
- Rubber-coated handle

Removable castors

2 removable tool panels.



7 kg

020370000



420x325x275 mm



4 removable pivoting castors for horizontal trolley handling.



2 TSA approved locks with keys

2038/TV

new item

Tool trolley, made of thick polypropylene, empty

- Highly shock resistant
- Aluminium sealing profile
- Telescopic handle and big ball bearing castors
- Capacious bottom
- Document pocket
- 3 tote drawers

• 2 ergonomic rubber-coated handles (including 1 side handle)

2 removable tool panels.



9 kg

020380000



430x500x340 mm



• 2 TSA approved locks with keys

Technical fabric Lightweight and sturdy, for absolutely



C5 Rucksack

- Removable interior tool panel
- Six exterior pockets and two interior pockets
 - Waterproof plastic base
 - Double safety lace for fixing rucksack to shoulders
 - Ergonomic padded back

500x400x180 mm

021050000



Bag opens at front for easier access to tools at workplace



C6T

Rucksack with castors

- Telescopic handle for easy transport
- Built-in castors with practical dustproof cover for use as a rucksack
- Two removable tool panels
- Interior PC pocket and five exterior pockets
- Waterproof plastic base

480x370x220 mm

021060010



C11 Box

- Hard water resistant plastic base
- Elastic tool bands and interior and exterior tool pockets
- Document holders built into double bottom of cover

021110000

C7

Bag

- 2 removable interior tool panels
- 2 exterior front pockets
- Interior bottom made of plastic, with removable partitions



440x370x170 mm

021070000



C9

Bag

- Hard base
- Interior and exterior tool pockets
- Double bottom
- Double string for levels
- Shoulder strap for easier transport

021090000



550x200x210 mm

tool bags

safe transportation of your tools

Containers

C12

Bag

- Removable interior tool panel
- Elastic tool bands and capacious interior and exterior pockets
- Hard, waterproof base with rubber feet



500x370x270 mm

021120000



400x240x220 mm



Box

- Hard frame
- Double bottom.
- Tilting handle for easier access to tools
- Elastic tool bands and interior and exterior pockets
- Cover
- Tool tray included in double bottom
- Can be used with trolley C8



C10

021100000

520x220x250 mm

C10S

021100001

420x220x250 mm



470x370x280 mm

021080000

C8

Trolley

- Telescopic carrying handle
- 2 removable interior tool panels
- Interior PC pocket and 2 exterior front pockets
- Can accommodate tool box item C10S



M10

024500010

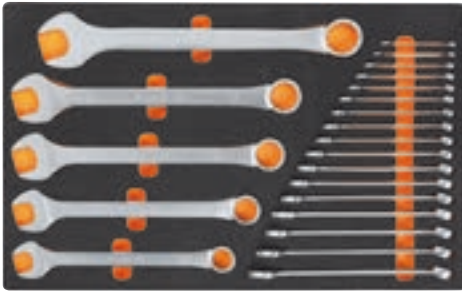

22

42 6-7-8-9-10-11-12-13-14-15-16-17-18-19-20-21-22-24-27-30-32-36 mm

M30

024500030



31

55 6x7-8x9-10x11-12x13-14x15-16x17-18x19-20x22-21x23-24x27-30x32 mm
90 6x7-8x9-10x11-12x13-14x15-16x17-18x19-20x22-21x23-24x27-30x32 mm
96BPC/SC9 1,5-2-2,5-3-4-5-6-8-10 mm

M60

024500060



24

○ 96T 2-2,5-3-4-5-6-7-8-10 mm
○ 97BTX/SC8 T9-T10-T15-T20-T25-T27-T30-T40
○ 944BX 5-6-7-8-10-13 mm

M63

024500063



8

○ 952 7-8-10-12-13-14-17-19 mm

M65

024500065

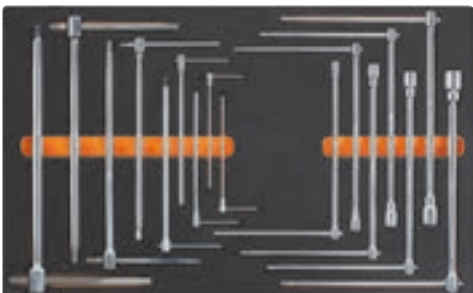

16

○ 950 8-10-12-13-14-17-19 mm
○ 951 2,5-3-4-5-6-8-10-12-14 mm

M100 12" 14"

024500100

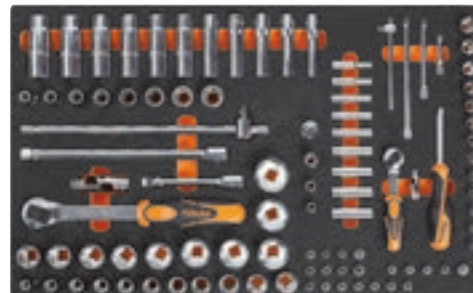

98

895/1 - 895/3 - 895/6
○ 900 4-4,5-5-5,5-6-7-8-9-10-11-12-13-14 mm
○ 900L 5-6-7-8-9-10-11-12-13 mm
○ 900ME 3-4-5-6-7 mm
● 900LP 0,8x4-1x5,5-1,2x6,5-1,2x8 mm
⊕ 900PH PH1-PH2-PH3-PH4
○ 900TX T10-T15-T20-T25-T27-T30-T40
900/20 50 mm - 900/20L 100 mm
900/21 150 mm
900/25 - 900BG/30 - 900/42
⊕ 900/55
○ 920A 8-10-11-12-13-14-15-16-17-18-19-20-21-22-23-24-26-27-28-30-32 mm
920/15 - 920/25
920AN/125 125 mm
920AN/250 250 mm
920/42
⊕ 920/55
⊕ 920FTX 10-12-14-16-18-20-22-24 mm
○ 920AL 10-12-13-14-15-16-17-18-19-21-22 mm

Thermoformed trays

M121 12"

024500121



46

- 920BP 5L-6L-8L-10L-5XL-6XL-8XL mm
- 920TX T20-T25-T27-T30-T40-T45L-T50L-T55L-T60L-T70L
- 920XZN 4-5-6-6L-8-8L-10-10L-12-12L-14-14L-16-18 mm
- 920ES 7-9-10-11-12L-14L-16L-7XL-9XL-10XL-11XL-12XL-14XL-16XL mm
- 920/36A

M120 12"

024500120



75

- 920A 10-11-12-13-14-15-16-17-18-19-20-21-22-24-26-27-30-32 mm
- 920AN/125 125 mm
- 920AN/250 250 mm
- 920/25 - 920/42
- 920AL 10-12-13-14-15-16-17-18-19-22-24-27-30-32 mm
- 920FTX 10-12-14-16-18-20-22-24 mm
- 920/55
- 920PE 5-5L-6-6L-7-7L-8-8L-10-10L-12-12L-14-14L
- 920TX T20-T25-T27-T30-T40-T45-T50-T55-T60-T20L-T25L-T27L-T30L-T40L-T45L-T50L

M130

024500130



13

- 1032 180 mm
- 1034 170 mm
- 1036 175 mm
- 1038 175 mm
- 1048 250 mm
- 1052 240 mm
- ⌘ 1082BM 160 mm
- 1098 220 mm
- 1112 250 mm
- 1128BM
- 1150BM 180 mm
- 1166BM 160 mm
- 1168BM 160 mm

M210

024500210



25

- 1201 2,5x50-3x75-4x100-5,5x125-6,5x150-8x200 mm
- 1201N 4x30 mm
- 1202 PH0x60-PH1x80-PH2x100-PH3x150 mm
- 1202N PH1X30 mm
- 1207TX T6-T7-T8-T9-T10-T15-T20-T25-T27-T30-T40-T45
- 1253

M230

024500230



25

- 30 Ø 2-3-4 mm
- 31 Ø 2-3-4-5-6-8 mm
- 32 Ø 4 mm
- 34 150 mm
- 35 200-250 mm
- 36 125 mm
- 1370 500 g
- 1390 Ø 35 mm
- 1692 3 m
- 1712
- 1719BMA/Q 200 mm
- ▲ 1719BMA/T 200 mm
- ▾ 1719BMA/P 200 mm
- 1719BMA/M 200 mm
- 1719BMA/R 200 mm
- 1737
- 1771 18 mm

M288 *new item*

024500288



9

- 1128BMX
- 1130BMX
- 1719BMA/Q 200 mm
- 1719BMA/P 200 mm
- 1719BMA/M 200 mm
- 1719BMA/R 200 mm
- 1726BM 400mm
- 1728BM (5)
- 1771BM 170 mm
- 1778V18 185 mm

T10

024240010



42 6-7-8-10-11-12-13-14
16-17-18-19-21-22-24-27-30 mm

T15

024240015



42 6-7-8-9-10-11-12-13-14
15-16-17-18-19-20-21 mm

T16

024240016



42 22-24-27-30-32

T31

024240031



31 Ø 2-3-4-5-6 mm
32 Ø 4 mm
55 6x7-8x9-10x11-12x13-14x15-16x17-18x19
20x22-21x23-24x26-27x29-30x32 mm
○ 96N/SC9 1,5÷10 mm

T40

024240040



90 6x7-8x9-10x11-12x13
14x15-16x17-18x19 mm

T45

024240045



142 8-9-10-11-12-13-14
15-16-17-18-19 mm

T46

024240046



142SN 8-9-10-11-12-13-14
15-16-17-18-19 mm

T50

024240050



○ 96T 2-2,5-3-3,5-4-4,5-5-6-7-8-10 mm

T55

024240055



○ 97TTX T10-T15-T20 T25-
T27-T30

T63

024240063



○ 952 7-8-10-12-13-14-17-19 mm

T83

024240083



12"
○ 920A 10-11-12
13-14-15-16-17-18
19-20-21-22-23-24
26-27-30-32 mm
920/21 125 mm
920/22 255 mm
920/25
920/42 305 mm
920/55 Ⓟ 275 mm

T85

024240085



14"
81
● 861LP 0,5x3-0,6x4,5-0,8x5,5-1x5,5
1,2x6,5-1,2x8-1,6x8 mm
○ 861PE 2-2,5-3-4-5-6-8-10 mm
⊕ 861PH PH0- PH1 - PH2 - PH3
⊕ 861PZ PZ1 - PZ2 - PZ3
○ 861TX T6-T7-T8-T9-T10-T15-T20-T25
T27-T30-T40
⊕ 861RTX T9-T10-T15-T20-T25-T27-T30-T40
⊕ 861TRW 1-2-3-4-5-6 mm
⊕ 861TQS 0-1-2-3-4-5-6-8 mm
⊕ 861SP 4-6-8-10-12 mm
851SR 230 mm
○ 900 4-4,5-5-5,5-6-7-8-9-10-11-12-13-14 mm
900/21 150 mm 900/25 41 mm
900BG/30 176 mm 900/42 115 mm
Ⓟ 900/55 125 mm 194 1/4x5/16

T91

024240091



14"
25
○ 900 4-4,5-5-5,5-6
7-8-9-10-11-12
13-14 mm
○ 900ME 2,5-3-4-5-6-8 mm
900/20 50 mm
900/21 150 mm
900/25
900BG/30 176 mm
900/42 115 mm
Ⓟ 900/55 125 mm

T92

024240092



3/8"
22
○ 910A 6-7-8-9-10-11-12
13-14-15-16-17-18
19-20-21-22 mm
910/21 125 mm
910/22 250 mm
910/25
910/42 210 mm
Ⓟ 910/55 200 mm

Thermoformed trays

T103 024240103



- 900L 6-7-8-9-10-11-12 mm
- 920AL 13-14-16-17-18-19
21-22-24-27 mm

T131 024240131



- 1084BM 160 mm
- 1150BM 180 mm
- 1166BM 160 mm

T145 024240145



- ⊙ 1032 180 mm
- ⊙ 1034 170 mm
- 1036 175 mm
- 1038 175 mm

T153 024240153



- 1048 250 mm
- 1052 240 mm

T199 024240199



- 1260 2,5x50 - 3x75
3,5x100 - 4x125 - 5,5x100
5,5x150-6,5x150 mm

T202 024240202



- ⊕ 1262 PH0x60 - PH0x100 - PH1x80
PH1x120 - PH2x100 - PH2x150 mm

T205 024240205



- ⊙ 1267TX
T6-T7-T8-T9-T10-T15-T20

T210 024240210



- 1201 2,5x50-3x75-3,5x100-
4x125- 5,5x100-5,5x150 6,5x150mm

T212 024240212



- ⊕ 1202 PH0x60-PH1x80
PH1x120-PH2x100
PH2x150-PH3x150 mm

T215 024240215



- ⊙ 1207TX
T6-T7-T8-T9-T10-T15-T20

T234 024240234

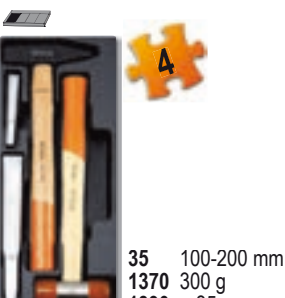

- 35 100-200 mm
- 1370 300 g
- 1390 ø 35 mm

T236 024240236



- 1719BMA/Q 200 mm
- ▲ 1719BMA/T 200 mm
- 1719BMA/P 200 mm
- ▶ 1719BMA/M 200 mm
- 1719BMA/R 200 mm

T239 024240239



- 31BM Ø 2-3-4-5-6-8 mm
- 32 ø 4 mm

42/SP15

Set of 15 combination wrenches with holder

☞ 6-7-8-9-10-11-12-13-14-15
16-17-19-22-24 mm



☞ 000420078

55/SP7

Set of 7 double open end wrenches with holder

☞ 6x7-8x9-10x11-12x13-14x15
16x17-18x19 mm



☞ 000550167

42/SC9I

Set of 9 combination wrenches, open and offset ring ends, with compact support

☞ 8-10-11-12-13-14-15-17-19 mm



☞ 000420087

142/SC9I

Set of 9 reversible ratcheting combination wrenches, with compact support

☞ 8-10-11-12-13-14-15-17-19 mm



☞ 001420087

142SN/SC9

Set of 9 swivel end ratcheting combination wrenches with compact support

☞ 8-10-11-12-13-14-15-17-19 mm



☞ 001420259

Wrenches

90/S7

Set of 7 double ended deep offset ring wrenches

6x7-8x9-10x11-12x13-14x15-16x17-18x19 mm

000900163



192/S2

Set of 2 reversible ratcheting offset bi-hex ring wrenches

001920070

8 sizes in 2 wrenches



195/B5

Set of 5 ratcheting double-ended flat bi-hex ring wrenches in wallet

8x10-12x13-14x15-16x18-17x19 mm

001950066



88/S7

Set of 7 double ended flat ring wrenches, extra-long series

EXTRA-LONG



000880107

mm	L mm
8x10	235
12x14	330
13x15	330
16x18	405
17x19	405
21x23	435
22x24	435

42INOX/SC9

Set of 9 combination wrenches made of stainless steel with compact support

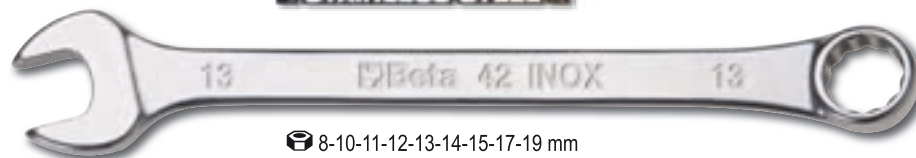

8-10-11-12-13-14-15-17-19 mm

000420387

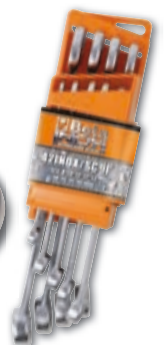

111

Adjustable wrenches with scales, chrome-plated

- Movable jaw opening with right-hand rotation of pin
- Head angled at 22.5 degrees, with mm and inch scale



mm/inch readout

	L mm	A max.		
111/100	100	15 mm	001110010	
111/150	150	24 mm	001110015	
111/200	200	28 mm	001110020	
111/250	250	34 mm	001110025	
111/300	300	35 mm	001110030	



933/S7

Set of 7 double ended offset hexagon socket wrenches

○ 8-10-11-12-13-17-19 mm



009330077



933/S12

Set of 12 double ended offset hexagon socket wrenches

○ 8-10-11-12-13-14-16-17-18-19-22-24 mm

009330089



944BX/D6

Set of 6 deep, hi-torque hexagon nut spinners long series

○ 5-6-7-8-10-13 mm



Betamax



009440056



952/D7

Set of 7 T-handle wrenches with swivelling hexagon sockets

○ 7-8-10-12-13-14-17 mm

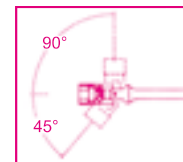
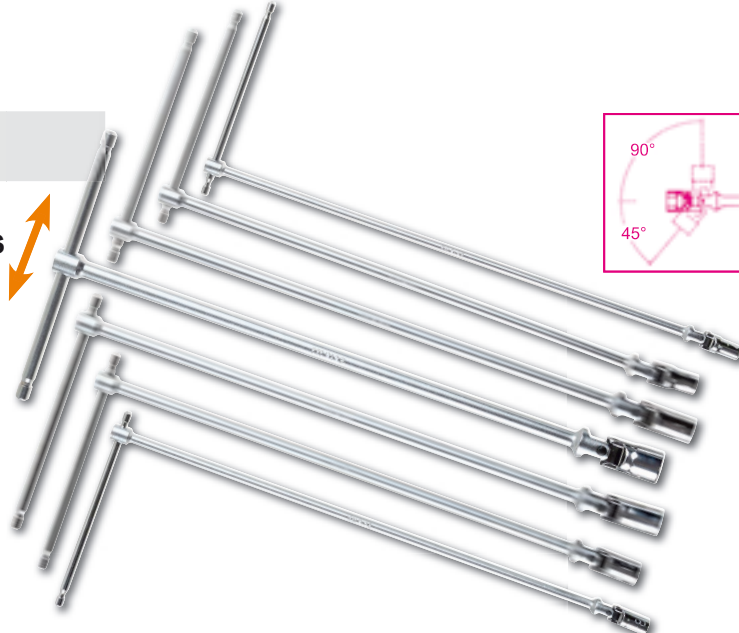

009520079



Male-end wrenches

96T/S5P



Set of 5 offset hexagon key wrenches with handles

○ 2,5-3-4-5-6 mm

000960946



951/S6



Set of 6 T-handle wrenches with three hexagon male ends

○ 2,5-3-4-5-6-8 mm



009510687

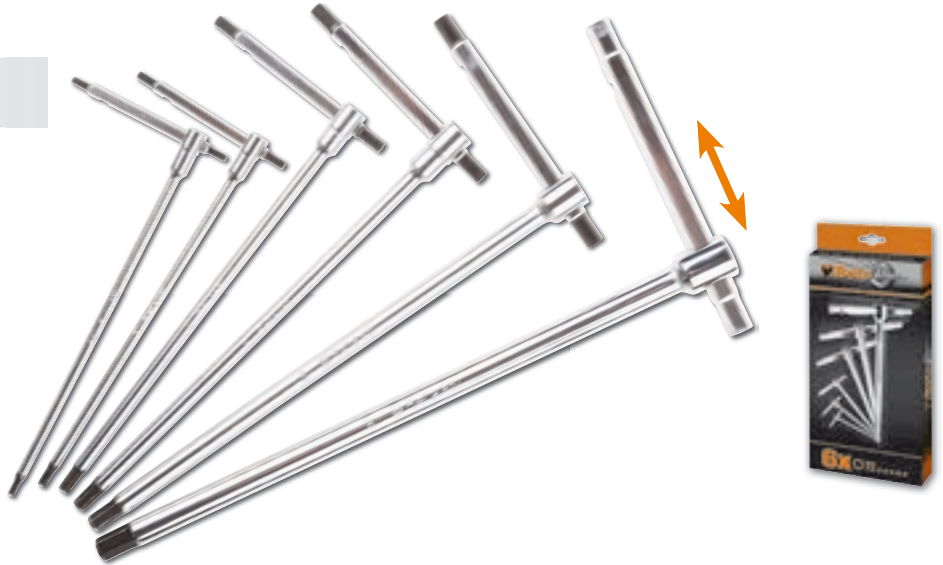

97TTX/S6



Set of 6 ball head offset key wrenches for Torx® head screws with handles

○ T10-T15-T20-T25-T30-T40

000970791



852 1/4



Bit holder with articulated T handle

008520006



wrench locking system

96BP-CO/SC9

Set of 9 ball head offset hexagon key wrenches, coloured



96BPC/SC9

Set of 9 ball head offset hexagon key wrenches



Find your size immediately!

96/SC9

Set of 9 offset hexagon key wrenches



Ø mm	L mm
1,5	91
2	100
2,5	113
3	130
4	142
5	163
6	185
8	205
10	231

Ø mm	L mm
1,5	42
2	48
2,5	59
3	62
4	70
5	81
6	92
8	102
10	116

Ø mm	L mm
1,5	79
2	85
2,5	89
3	100
4	110
5	129
6	152
8	173
10	194

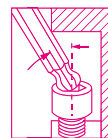
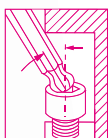

000961519

000960374

000960354



96LBP/SC9

Set of 9 ball head offset hexagon key wrenches



97BTX/SC8

Set of 8 ball head offset key wrenches, for Torx® head screws



new item

97BTXL/SC8

Set of 8 ball head offset key wrenches, long model, for Torx® head screws

Ø mm	L mm
1,5	91
2	100
2,5	113
3	130
4	142
5	163
6	185
8	205
10	231

Ø mm	L mm
T9	65
T10	74
T15	84
T20	96
T25	98
T27	109
T30	123
T40	136

Ø mm	L mm
T9	83
T10	89
T15	103
T20	114
T25	130
T27	145
T30	166
T40	183

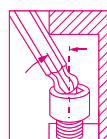

Extra-long model

Extra-long model +30%

000961354

000970164

000970364

new item



335x145x60 mm



867/C20

Assortment of 18 bits for RIBE® screws, with 10 mm hexagon drive and 2 accessories, in soft foam tray and metal case

	867/1	L 38 mm	○ 10 mm - □ 3/8
	867/2	L 38 mm	○ 10 mm - □ 1/2
	867RIBE	⊗ L 30 mm	5-6-7-8 -9-10 -11-12-13 mm
	867RIBE/L	⊗ L 75 mm	5-6-7-8 -9-10 -11-12-13 mm

008670920

New bit holder with articulated T handle

852

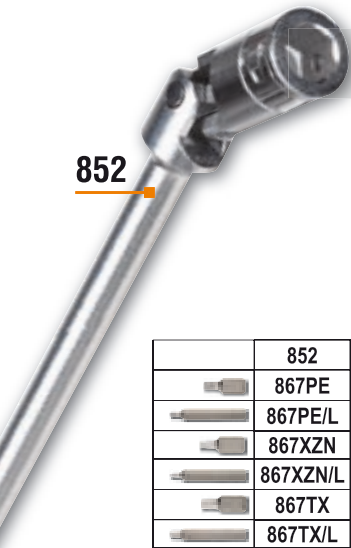

867/C38



Assortment of 38 hexagon bits, 10 mm, and 1 bit holder with articulated T handle, in foam tray and metal case

	852	○ L 400 mm	10 mm
	867PE	○ L 30 mm	4-5-6-7-8-10-12 mm
	867PE/L	○ L 75 mm	4-5-6-7-8-10-12 mm
	867XZN	○ L 30 mm	M5-M6-M8-M10-M12
	867XZN/L	○ L 75 mm	M5-M6-M8-M10-M12
	867TX	⊗ L 30 mm	T20-T25-T30-T40-T45-T50-T55
	867TX/L	⊗ L 75 mm	T20-T25-T30-T40-T45-T50-T55



008670938

420x185x60 mm

new item

860/C27



Set of 25 bits, 1 connector and 1 reversible ratchet in plastic case

- 860LP 0,5x3-1,0x5,5-1,2x6,5 mm
- 860PE 2-2,5-3-4-5-6-mm
- 860PH PH1-PH2(x2)-PH3
- 860TX T6-T8-T10-T15-T20-T25-T30-T40
- 860PZ PZ1 - PZ2(2x) - PZ3
- 860/55 100 mm
- 892/0



008600880

862F/A7



Set of 7 magnetic bits, hexagon sockets, in plastic case

862F ○ 5,5-6-7-8-10-12-13 mm



008620950



Screwdrivers



1203/D8P

Set of 8 screwdrivers

- 1201 ● 2,5x50-3x75-4x100-5,5x100-6,5x150 mm
- 1202 ⊕ PH0x60-PH1x80-PH2x100 mm

012030018



1203/D10N

Set of 10 screwdrivers

- 1201 ● 2,5x50-3x75-4x100-5,5x150-6,5x150 mm
- 1202 ⊕ PH0x60-PH1x80-PH2x100 mm
- 1201N ● 4x30 mm
- 1202N ⊕ PH1x30 mm

012030019



1207TX/D7

Set of 7 screwdrivers

- 1207TX ⊕ T6-T8-T10-T15-T20-T25-T30

012070207



1263/D8

Set of 8 screwdrivers

- 1260 ● 2,5x50-3x75-4x100- 5,5x125-6,5x150 mm
- 1262 ⊕ PH0x60-PH1x80- PH2x100 mm

012630008



1263/D10

Set of 10 screwdrivers

- 1260 ● 3x75-3,5x100-4x125-5,5x150-6,5x150 mm
- 1262 ⊕ PH0x60- PH1x8-PH2x100 mm
- 1260N ● 4x30 mm
- 1262N ⊕ PH1x30 mm

012630010



1267TX/D7

Set of 7 screwdrivers

- 1267TX ⊕ T6-T8-T10-T15-T20-T25-T30

012670307



1293/D8

Set of 8 screwdrivers

- 1291 ● 3x75-4x100-5,5x100-6,5x150-8x150 mm
- 1292 ⊕ PH0x60-PH1x80-PH2x100 mm

012930403



1293INOX/D8

Set of 8 screwdrivers made of stainless steel

- 1290INOX ● 2,5x50-3x75-4x100-5,5x150-6,5x150 mm
- 1292INOX ⊕ PH0x60-PH1x80-PH2x100 mm

012930408



1273MQ/D6

Set of 6 screwdrivers

- 1274MQ ● 3x100-4x100-5,5x125 mm
- 1272MQ ⊕ PH0x60-PH1x80-PH2x100 mm

012730851



1000 V

Can be extended by up to an additional 70% vs. standard

920/55L

12"

72

Extension reversible ratchet

- 1/2" male drive
- 72 tooth mechanism



7 different lengths
280 to 422 mm

009200927



1/4"

3/8"

1/2"

Reversible ratchet with rotating handle

- Socket release button
- Ring nut reversal system on ratchet head
- Bi-material handle

Rotating the handle clockwise and anticlockwise will make the bit turn quickly

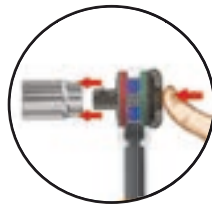

A mm

Ø mm

	L mm	Ø mm	A mm	■		
900/58	126	28	28,5	1/4"	009000884	
910/58	222	37	38,5	3/8"	009100884	
920/58	281	42,5	45	1/2"	009200926	

1/4"

3/8"

1/2"

3/4"

Reversible ratchet chrome-plated



A mm

Ø mm

48

72

72

72

	L mm	Ø mm	A mm	■		
900/55	125	25	18	1/4"	009000870	
910/55	200	30	33	3/8"	009100882	
920/55	275	40	43	1/2"	009200882	
928/55	510	58	59	3/4"	009280862	



Assortment of 11 hexagon sockets, 21 bits and 7 accessories in plastic case



900/C39

reversible ratchet (900/55)

009000937



	861LP	●	0,6x4,5-1,2x6,5-1,2x8 mm
	861PE	○	2,5-3-4-5-6 mm
	861PH	⊕	PH1-PH2-PH3
	861PZ	⊕	PZ1-PZ2-PZ3
	861RTX	⊕	T10-T15-T20-T25-T27-T30-T40 mm
	892/0	●	1/4" - 1/4"
	895/1	○	1/4" - 1/4"
	900	○	5-5,5-6-7-8-9-10-11-12-13-14 mm
	900/20		50 mm
	900/20L		100 mm
	900/25		
	900BG/30C		

900/C39-R

reversible ratchet with rotating handle (900/58)

009000938



Assortment of 12 hexagon sockets, 20 bits and 7 accessories in metal case



900/C12M

reversible ratchet (900/55)

009000963



350x150x50 mm

	861LP	●	0,5x3-0,8x5,5-1x5,5-1,2x6,5 mm
	861PE	○	3-4-5-6-8 mm
	861PH	⊕	PH0-PH1-PH2-PH3
	861TX	○	T8-T10-T15-T20-T25-T30-T40
	895/1	○	1/4" - 1/4"
	900	○	4-5-5,5-6-7-8-9-10-11-12-13-14 mm
	900/20		50 mm
	900/21		150 mm
	900/25		
	900/42		
	900BG/30		

900/C12MR

reversible ratchet with rotating handle (900/58)

009000962



902A/C22



Assortment of 22 hexagon sockets and 6 accessories in metal case



1/4"		900	○	5-5,5-6-7-8-9-10-11-12-13 mm
		900/20		50 mm
		900/25		
		900/55	⊕	
1/2"		920A	○	10-13-14-15-17-18-19-22-24-27-30-32 mm
		920/21		125 mm
		920/25		
		920/55	⊕	

009020807

420x185x60 mm

38"



Assortment of 16 hexagon sockets and 5 accessories in foam tray, in metal case

910A/C16

reversible ratchet (910/55)

009100936



335x145x60 mm

	910A	6-7-8-9-10-11-12-13-14 15-16-17-18-19-21-22 mm
	910/21	125 mm
	910/22	250 mm
	910/25	
	910/42	

910A/C16HR

reversible ratchet with rotating handle (910/58)

009100935



12"



Assortment of 17 hexagon sockets and 5 accessories in foam tray, in metal case

920A/C17M

reversible ratchet (920/55)

009200924



420x185x60 mm

	920A	10-11-12-13-14-15-16-17-18-19 20-21-22-24-27-30-32 mm
	920/21	125 mm
	920/22	255 mm
	920/25	
	920/42	

920A/C17MR

reversible ratchet with rotating handle (920/58)

009200937



928A/C12

34"



Assortment of 12 hexagon hand sockets and 5 accessories in metal case

	928A	22-24-27-30-32-34-36-38-41 46-50-55 mm
	928/21	200 mm
	928/22	380 mm
	928/25	
	928/42	
	928/55	

009280955

530x220x80 mm



Click-type torque wrenches

605E 1/4"

Click-type torque wrenches with reversible ratchets for right-hand and left-hand tightening torque accuracy: $\pm 6\%$



UNI EN 26789 ISO 6789



	Nm	kgfm	lbf.ft	■	L (mm)	g		
605E/5	1÷5	0,1÷0,5	10÷45	1/4"	190	180	006050105	
605E/10	2÷10	0,2÷1,0	18÷90	1/4"	190	180	006050110	

666N

1/4" 3/8"



new item

Click-type torque wrenches with reversible ratchets
For right-hand and left-hand tightening
Torque accuracy: $\pm 3\%$

- Scale increased by 60% for improved visibility and setting accuracy
- Torque adjusting speed increased by 40%
- Handle and lens materials resistant to all chemical substances used in automotive sector, industry and aviation



UNI EN 26789 ISO 6789



	Nm	kgfm	lbf.ft	■	L (mm)	g		
666N/2	5÷25	0,5÷2,5	4÷18	1/4"	215	300	006660002	
666N/2X	5÷25	0,5÷2,5	4÷18	3/8"	215	300	006660003	

606

3/8" 1/2"



Click-type torque wrenches with reversible ratchets
for right-hand tightening torque accuracy: $\pm 4\%$



UNI EN 26789 ISO 6789



	Nm	kgfm	lbf.ft	■	L (mm)	g		
606/6	8÷60	0,8÷6	6÷44	3/8"	305	595	006060105	
606/10X	20÷100	2÷10	15÷80	1/2"	345	680	006060111	
606/20	40÷200	4÷20	30÷150	1/2"	440	920	006060120	
606/30	68÷330	6÷33	40÷250	1/2"	560	1180	006060130	

Torque wrenches



677/C **3/4"**

Break-back torque wrenches with push-through ratchets, for right-hand and left-hand tightening, torque accuracy: $\pm 4\%$ in case



UNI EN 26789 ISO 6789

677/C100

	Nm	kgfm	lbf.ft	■	L (mm)	kg		
677/C50	100÷500	10÷50	70÷350	3/4"	915	5,2	006770606	
677/C70	150÷700	15÷70	100÷500	3/4"	1140	6,2	006770611	
677/C100	300÷1000	30÷100	200÷750	3/4"	1470	7,5	006770615	



599DGT-A **1 1/2"**

UNI EN 26789
ISO 6789

Electronic direct reading torque wrench, for right-hand and left-hand tightening, torque accuracy: $\pm 2\%/\pm 3\%$, in case



Angle readout up to 360°!



- Reversible ratchet
- LCD display
- Unit of measurement: Nm, ft.lb, in.lb, kgcm
- Dual approaching/stopping signal
- Power supply: 2 AA 1.5V batteries (included)



	Nm	∠	kgfm	lbf.ft	■	L (mm)		
599DGT-A/10	20÷100	0÷360°	2÷10	15÷80	1/2"	413	005990510	
599DGT-A/20	40÷200	0÷360°	4÷20	30÷150	1/2"	520	005990520	



561/1 *Compact and light*

Torque multiplier, ratio 5:1 with two reaction feet

- Supplied with straight lever and 90° foot
- Ideal for use in small areas (body \varnothing 65mm)
- Ultralightweight (1.5 kg)
- Measuring range: 100÷1000 Nm
- Female drive: 1/2"
- Male drive outlet: 3/4"
- For right-hand and left-hand tightening
- Torque accuracy: $\pm 4\%$

005610010

\varnothing 65 mm

new item





1169BM/D3

Set of 1 combination pliers, 1 long needle nose pliers and 1 diagonal cutting nippers



011690123



1082BM 160 mm



1166BM 160 mm



1150BM 180 mm

1169MQ/D2

Assortment of insulated combination pliers and insulated diagonal cutting nippers

1000 V

011690143



1150MQ 180 mm



1182MQ 160 mm



1009L/DP-S2

Set of 2 extra-long, knurled double swivel nose pliers

• Suitable for jobs in hard-to-access areas



L 340 mm



45°



1009L/DP

1009L/D

010090060

1052

Adjustable self-locking pliers, concave jaws

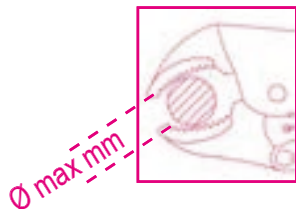

	L mm	Ø Max mm		
1052/140	140	22	010520014	
1052/190	190	36	010520019	
1052/240	240	42	010520024	

1047/240

Slip joint pliers, push button alignment

- Quick, accurate adjustment by pressing push button
- No accidental misadjustment
- Heat-treated jaws



 **010470240**

L 240 mm Ø Max 36 mm  Max 32 mm

1048

Slip joint pliers, boxed joints

- Slip joint pliers, boxed joints



 **010480015**



9-position model

1031/S4

Set of 4 circlip pliers



1038 175 mm
● 19 ÷ 60 mm

1036 175 mm
● 19 ÷ 60 mm

1032 180 mm
○ 19 ÷ 60 mm

 **010310000**

1034 170 mm
○ 19 ÷ 60 mm

Hammers and chisels

38/B6

Set of 6 drift punches, centre punches, flat chisels and cape chisels, in wallet

000380006



30: Ø 2-3 mm

32: Ø 4 mm

34: 125-150 mm

36: 150 mm



32AU

Automatic centre punches

000320160



L 150 mm



1370

Engineer's hammer, wooden shaft

	g		
1370/200	200	013700052	
1370/300	300	013700053	
1370/400	400	013700054	
1370/500	500	013700055	
1370/600	600	013700056	
1370/800	800	013700058	
1370/1000	1000	013700060	
1370/1500	1500	013700065	

1390

Soft face hammers, wooden shafts

	Ø mm		
1390/22	22	013900022	
1390/28	28	013900028	
1390/35	35	013900035	
1390/45	45	013900045	
1390/60	60	013900060	

1380

Lump hammers, wooden shafts

	g		
1380/800	800	013800208	
1380/1000	1000	013800210	
1380/1250	1250	013800212	
1380/1500	1500	013800215	
1380/2000	2000	013800220	

Drilling and threading tools

412/SP19P

Set of 19 twist drills with cylindrical shanks, HSS, entirely ground glossy finishing

R ≤ 700 N/mm²
HV ≈ 750÷820
Ø 1÷10 x 0,5 mm

115x170x40 mm

004120429



415CO/SP19A

Set of 19 twist drills with cylindrical shanks, HSS-CO 5%

- For drilling holes into STAINLESS steel, alloy steel, cast iron, mild steel, light alloys

R ≤ 1400 N/mm²
HV ≈ 850÷920
Ø 1÷10 x 0,5 mm

115x170x40 mm

004150440



425E/SP3

new item

Set of 3 stepped drills, HSS, enhanced grinding efficiency

Ø 4÷12 ; 4÷20 ; 4÷30 mm



004250600

437U/09

Assortment for repairing damaged threads

M5X0,8
M6X1,0
M8X1,25
M10X1,5
M12X1,75



004370550

370x230x55 mm

446/C110

Assortment of 105 chrome-steel taps and dies, metric thread, and 5 accessories for car repair jobs in wooden case

430 M mm	433 M mm	440/440A M mm	441/441A M mm
2x0,4	6x0,75 - 7x0,75	2x0,4	6x0,75 - 7x0,75
3x0,5	8x0,75 - 8x1	3x0,5	8x0,75 - 8x1
4x0,7	9x0,75 - 9x1	4x0,7	9x0,75 - 9x1
5x0,8	10x0,75 - 10x1	5x0,8	10x0,75 - 10x1
6x1	10x1,25 - 11x0,75	6x1	10x1,25 - 11x0,75
7x1	11x1 - 11x1,25	7x1	11x1 - 11x1,25
8x1,25	12x0,75 - 12x1	8x1,25	12x0,75 - 12x1
9x1,25	12x1,25 - 12x1,5	9x1,25	12x1,25 - 12x1,5
10x1,5	14x1 - 14x1,25	10x1,5	14x1 - 14x1,25
11x1,5	14x1,5 - 16x1	11x1,5	14x1,5 - 16x1
12x1,75	16x1,5 - 18x1,5	12x1,75	16x1,5 - 18x1,5
14x2		14x2	
16x2		16x2	

435/0 444/1 436/1
435/3 444/2



004460060

500x337x60 mm

Patented

1128BAX

Double-acting electricians' scissors, with milling profiles in DLC-coated stainless steel



*+ hardness
- coefficient of friction*

DLC coating:

DLC (diamond-like carbon) is an innovative carbon-based coating: the high hardness and low coefficient of friction arise from the simultaneous presence of carbon on the surface in the form of graphite, and diamond.

- High blade surface hardness (resistance to abrasion and wear)
- Low coefficient of friction (smoothness and anti-adherence)
- Anti-loose eccentric pin
- With articulated plastic case

011280088



Profile and mill:
designed to enlarge holes on plastic, from 13 mm to 24 mm.

*Double-acting cutting
- effort + power*

a special cam on the fulcrum reduces of 20% shear stress



1726

Hacksaw frame, blade attachment system in the handle

- hacksaw frame, aluminium handle

017260001



1771

Utility knife, 18 mm, supplied with 3 blades

017710000



1778V18

Foldaway knife, aluminium handle in case

017780018



new item

Measuring tools

Digital vernier made from hardened stainless steel

- in hard plastic case
- Reading to 0.01 mm
- Screw slider locking
- Mm/inch conversion

DIN 862

UNI EN ISO 13385-1



A Max 150 mm L 225 mm

1651DGT/150

016510111

A Max 200 mm L 285 mm

1651DGT/200

016510112

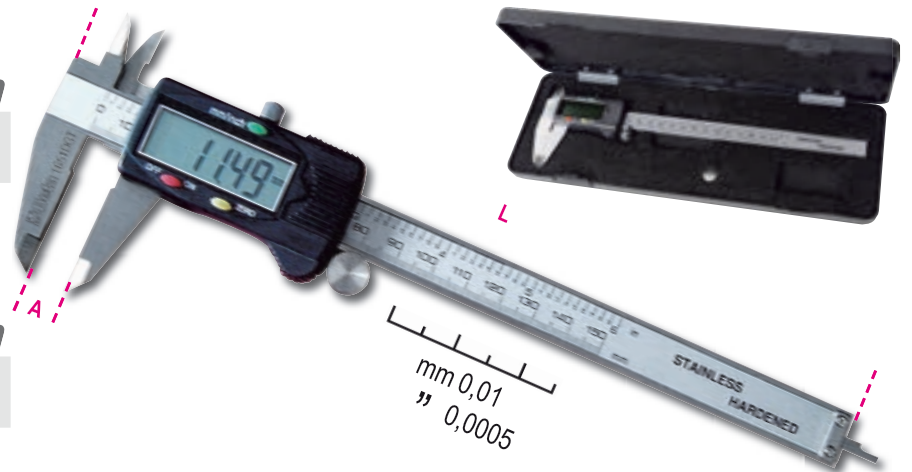

1691BM



Measuring tapes shock-resistant bimaterial ABS casings, steel tapes, precision class: II



	L m	S mm		
1691BM/5	5	25	016910205	
1691BM/8	8	32	016910208	
1691BM/10	10	32	016910210	

1430/S8

Set of 8 tapered extractors for broken screws and studs, made from hardened steel (item 1430/..), in plastic case

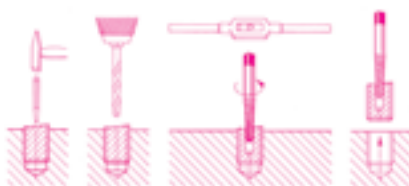

	M	A mm
1430/1	3÷6	2,5
1430/2	6÷8	3,0
1430/3	8÷11	4,5
1430/4	11÷14	6,0
1430/5	14÷18	8,0
1430/6	18÷24	11,0
1430/7	24÷33	14,0
1430/8	33÷50	21,0

014300108



1511

External pullers
with two reversible legs

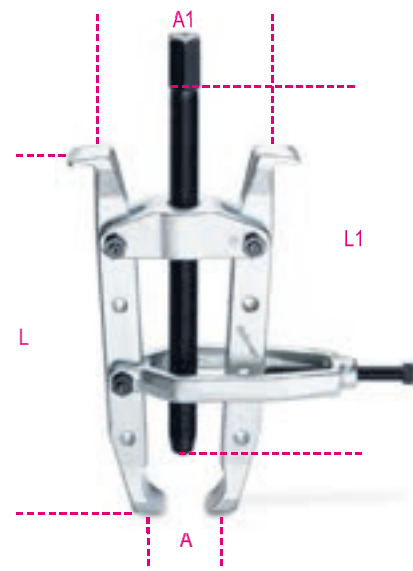

	A min÷Max	L mm	L1 mm	● mm	A1 min÷Max mm	Charge Max kg		
1511/1	20÷100 mm	235	230	19	65÷95	5000	015110001	
1511/2	40÷150 mm	330	340	22	103÷190	10000	015110002	
1511/3	40÷150 mm	405	400	22	103÷175	10000	015110003	

1500

Two - leg universal puller

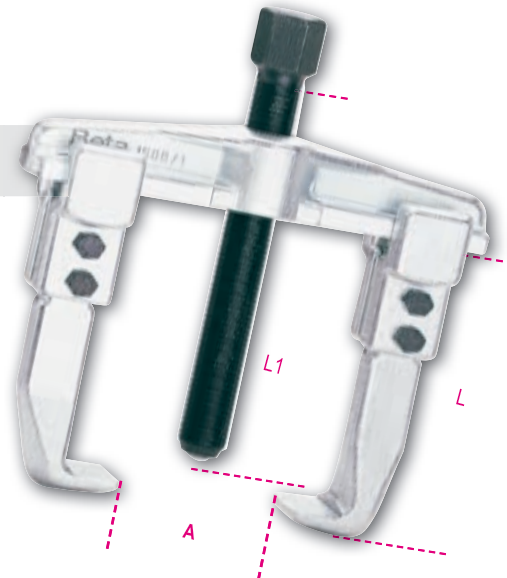
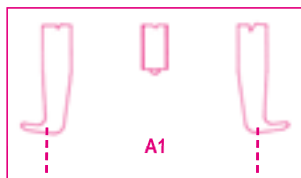

	A min÷Max	L mm	L1 mm	● mm	A1 min÷Max mm	Charge Max kg		
1500/1	25÷80 mm	100	135	17	70÷130	4500	015000301	
1500/2	25÷130 mm	100	135	17	80÷180	4500	015000302	
1500/3	50÷160 mm	150	210	22	105÷220	6000	015000303	
1500/4	60÷200 mm	150	210	22	120÷270	6000	015000304	

1428/SB11

Set of pullers for damaged
nuts square drive
with support

3/8" 8-10-11-12-13-14 mm **1/2"** 15-16-17-18-19 mm



014280111



Pullers

Puller kits

1533PR

1533

1534



1535/C1

	L mm	A min÷Max
1533PR/1	100	
1533/2	150	45÷130 mm
1534/1	88	5÷60 mm

260x180x40 mm

015350001

1535/C2

	L mm	A min÷Max
1533PR/1	100	
1533/2	150	45÷130 mm
1534/2	118	12÷75 mm

260x180x40 mm

015350002

1535/C3

	L mm	A min÷Max
1533PR/2	100	
1533/3	210	85÷225 mm
1534/3	160	22÷115 mm

380x280x55 mm

015350003

1547/C6

Dummy ball bearing extractors

- quick, safe extraction



015470006



Bearings

1547/1

6011-6014, 6206-6211, 6303-6308, 6403-6405

1547/2

6004-6010, 6200-6205, 6300-6304



420x185x60 mm



1545/C5M

Puller 1542/1
with 5 extractors 1544
in metal case

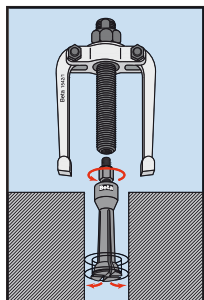

015450011



420x185x60 mm

	A mm	C mm
1544/1	9÷12	0,80
1544/2	13÷17	1,15
1544/3	16÷21	1,70
1544/4	20÷25	1,65
1544/5	25÷30	2,00

378

Pipe wrenches,
Swedish pattern, 45° slim jaws



	L mm	Ø Max	Ø Max		
378/320	320	1" gas	34 mm	003780032	
378/410	410	1"1/2 gas	49 mm	003780041	
378/550	550	2" gas	60 mm	003780055	

360

Pipe wrenches, Stillson pattern



	L mm	Ø Max	Ø Max		
360/350	350	1"1/2 gas	49 mm	003600035	
360/450	450	2 gas	60 mm	003600045	
360/600	600	2"1/2 gas	76 mm	003600060	

334

Pipe cutter for copper
and light
alloy pipes

003340001



Ø 3÷30 mm
1/8"÷1"1/8

351C

Pipe cutter and tube flaring tool
in plastic case



351P Ø 4-4,75-6-8-10-12-14 mm

003510010



225x150x45 mm



334 Ø 3÷30 mm
1/8"÷1"1/8



350 Ø 4÷14 mm

Plumbing tools

342

Ratchet-type shears
for plastic pipes

003420030



Ø 0÷42 mm
1"5/8

388C/C8

Pipe bender with 7 forms,
made of aluminium,
for soft copper and light
alloy pipes
in plastic case



400x330x110 mm



003880200



Ø mm 10,12,14,16,18,20,22

345C

new item

Multilayer pipe gauge

003450032



186 8-32

Self-locking wrench
with automatic take-up
device, for hexagons,
8 to 32 mm

Ideal for hexagon, Spline, square
and Torx® head screws,
including damaged screws.

001860008



L 260 mm

*Effective
on worn screws*

SPLINE®
12 sides Square Torx® Hexagonal 70%
rounded bolt



1149F

Front wire stripping pliers
with cutting blade, self-adjusting



0,2÷6 mm²

011490010

1606A/C9

Crimping pliers for tubular terminals
with assortment of 450 terminals, 0.5÷6 mm²



420x350x35 mm

016060100

1609B

Mechanical crimping pliers

- For noninsulated copper terminals, 10÷120 mm²
- Antislip rubber handle
- Internal "H" section pin for unparalleled punch smoothness
- Made from burnished steel



10÷120 mm²

L 600 mm

016090101

1256/C36-2

For precision jobs

Bi-material microscrewdriver with 36 interchangeable
4-mm bits and magnetic extension

130x60x35 mm

	1256TX	⊗	T3-T4-T5-T6-T7-T8-T9-T10-T15
	1256RTX	⊗	T6-T7-T8-T9-T10
	1256LP	●	0,8-1,2-1,5-1,8-2-2,5-3-3,5-4 mm
	1256PE	⊙	0,7-0,9-1,3-1,5-2 mm
	1256PH	⊕	PH000-PH00-PH0-PH1
	1256PZ	⊕	PZ000-PZ00-PZ0-PZ1
	1256/20		
	1256/30		

012560100



General maintenance tools

1760/RMS



Shockproof: tested for falls up to 2 metres

Industrial digital multimeter accurate and sturdy, in a 6-mm co-moulded shell, with antislip, shockproof outer rubber part

- Water protection IP67
- Protection up to 1000V
- Tested for accidental falls up to 2 m
- Protected inlets • Autoranging
- Large direct reading display, backlit, blue
- K type temperature probe (included) • Self-power down
- Rubber terminal base for enhanced operating comfort
- Double insulated terminals, 1000V, 1 m long
- Supplied in a soft case • CAT IV 600V/ CAT III 1000V
- Actual effective value TRUE RMS



017600020

	Measuring range	Base accuracy
AC/DC voltage	110mV – 600V ±0.8%	- ±2% rdg
AC/DC current	110µA – 10A ±1.5%	- ±2% rdg
Resistance	110Ω – 40MΩ ±1.2%	- ±2.5% rdg
Capacity	11nF – 40mF ±5%	- ±10% rdg (up to 11mF)
Frequency	1100Hz – 110 MHz ±1.2%	- ±1.5% rdg
Temperature	-32°C – +1000°C ±3%	- ±5% rdg
Diode test	3V DC ±10% rdg	
Continuity test	<30 Ω	

1740B 330

Compact heavy-duty riveting pliers

- Optimized lever ratio for increased compactness and handiness.
- 3 jaws lock rivet for a perfect grip.
- Adjustable head for pulling rivet by 2 to 5 leg movements.

3,2÷6,4 mm steel



3 jaws: improved rivet grip

With stem tank



017400330

1741B

Riveting pliers supplied with 4 interchangeable nozzles

017410000



1741U

Ultra compact riveting pliers with adjustable force
with 4 interchangeable nozzles

017410450



3 legs: enhanced rivet hold

L 200 mm



1749AC

High thrust gun
for chemical binders

017490005



1750 500

Lever operated grease guns,
500 cc

017500500



1750TA

new item

High-pressure, self-locking
6-pin grease nozzle

- Easy to disconnect, even when with pressurized nozzle
- Thread M10x1: suitable for all types of grease guns: electric, pneumatic, manual etc.
- Deformation-free up to 550 bar

017500111

SELF-LOCKING

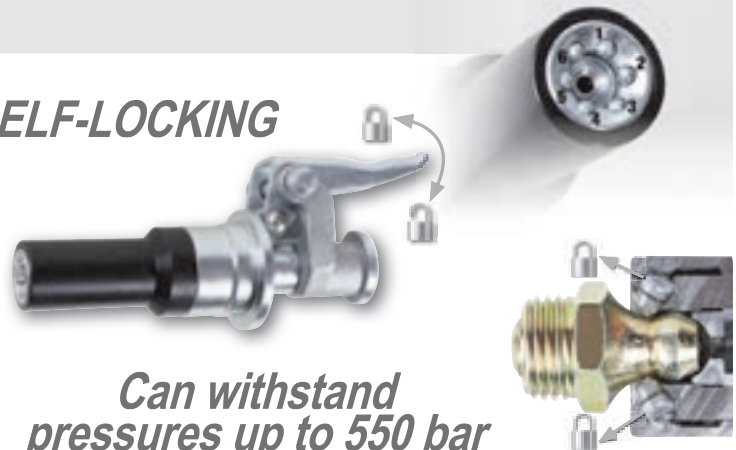

Suction guns, made of polypropylene

- Double gasket
- Operating temperature: +0 ÷ +50 °C
- Not suitable for fuel and mineral oil

1756C

017560502

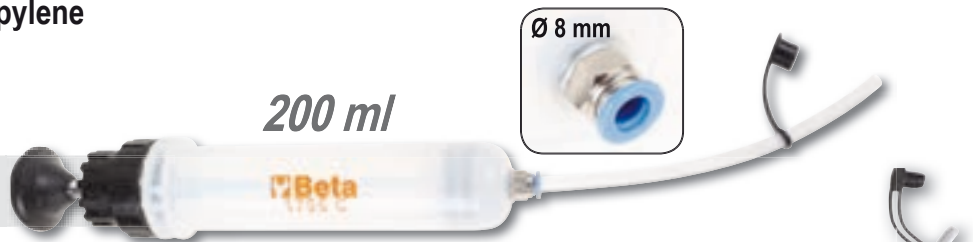

Also suitable for braking system fluid

1756D

017560515



Double NBR gasket

Technical data:

	1870	1871M	1872L
voltage:	230/240 V	230/240 V	230/240 V
frequency:	50/60 Hz	50/60 Hz	50/60 Hz
max. power:	1200 W	1200 W	1100 W
airflow rate:	58 l/sec.	60 l/sec.	55 l/sec.
max. suction power:	190 mbar	220 mbar	220 mbar
max. drum capacity:	20 l	35 l	35 l
acoustic emissions:	<70 dB(A)	<68 dB(A)	<68 dB(A)
cable length	5 m	7 m	6 m

STANDARD ACCESSORIES, Ø 36 mm:

	1870	1871M	1872L
corrugated hose:	✓	✓	✓
hard tubes:	✓	✓	✓
multiuse brush:	✓	✓	✓
flat nozzle:	✓	✓	✓
rubber fitting inside Ø	x	26 mm	x
FILTERING SYSTEMS			
air filter cartridge:	✓	✓	✓
anti-foam filter:	✓	✓	✓
bag:	x	✓	✓

1870 *Non-marking wheels*

Solid and fluid vacuum cleaner, 20 l



M class certified

1871M

Solid and fluid vacuum cleaner, 35 l, with service power and compressed air outlets

L class certified

1872L

Solid and fluid vacuum cleaner, 35 l



7042LCD



Auto-darkening LCD mask, for electrode welding; MIG/MAG; TIG and plasma. Solar cells power supply and lithium batteries for outstanding LCD filter life

- Viewing area: 98x43 mm
- Darkening shade: DIN 9-13, externally adjustable
 - UV/IR protection
- Light to dark time: 1/25000 s
- Dark to light time: 0.25-1s
- Adjustable darkening sensitivity and delay
 - Auto on/off
 - Grinding feature
- Optimized shape to make it easier to breathe with pulled-down screen

070420001



new item



DC inverter welding machines for MMA and TIG electrode steel welding. Compact and easy to carry. Arc force, hotstart, anti-sticking and thermostatic protection features



1860 160A

018600006



1860 140A 1860 160A

Adjustment current:	5÷140A	5÷160A
Power supply:	1x230V	1x230V
Use factor :	25% - 140 A 60% - 100 A 100% - 90 A	30% - 160 A 60% - 130 A 100% - 110 A
Delayed fuse:	16 A	25A
Protection:	IP23S	IP23S
Use with generators:	✓	✓
Cable:	16 mm ²	25 mm ²

1860 140A

018600004

1852R1750

Portable induction heater

- heats and loosens stubborn bolts, hubs and bearings without using flames
- allows any type of ferromagnetic metal to be heated.

Technical data:

- input voltage: 230V AC, 50/60 Hz
- input current: max. 7.5 A
- power: max. 1.75 kW

BENEFITS

- 1 - Time saving: quick, extremely accurate heating
- 2 - Fire safety: does not produce flames, maximum operator safety
- 3 - Functional: can be used with one hand, and coils can be easily interchanged

FIELDS OF APPLICATION

- Automotive industry
- Industrial maintenance
- Aviation industry
- Naval industry
- Petrochemical industry

Standard equipment:

- two front attachable coils, Ø 19 and 26 mm, for loosening nuts ①
- one flat coil for heating surfaces ③
- one flexible coil, 800 mm long ②
- supplied in plastic case



Maximum safety without using flames



018520175

480x370x130 mm

General maintenance tools

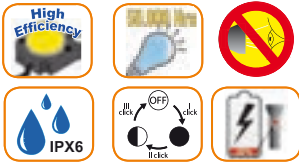

anodized aluminium

High-brightness LED torch, made of sturdy,

1350 LUMEN
1834P XL
 018340330
 3xD
 Not included

500 LUMEN
1834P L
 018340325
 1xAA
 2xAA
 3xAA
 Not included

350 LUMEN
1834P M
 018340320
 1xAAA
 2xAAA
 3xAAA
 Not included

300 LUMEN
1834P S
 018340310
 2xAA
 Not included



1836A

LED headlamp, dual brightness, with contactless ON/OFF sensor



- 120/65 lumens
- IP54
- Batteries: 3xAAA included

018360050



1837N



Magnetic, articulated lamp with high-brightness LEDs, up to 400 lumen

- Batteries (not included) :
 - 1xAA (life 20/60 h)
 - 2xAA (life 28/84 h)w
 - 3xAA (life 36/108 h)
- Lumens: 400>40>OFF
- Charge indicator
- Adjustable focus
- IPX6

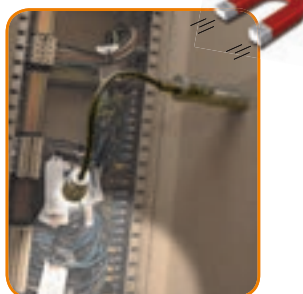
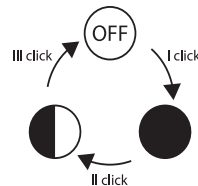
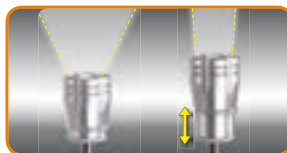

018370002



1838COB



Compact rechargeable inspection lamp with ultra-brightness LED. Lithium polymer battery

- Compact body made of antislip rubber
- Swinging hook
- Magnetic base can be rotated 180 degrees
- With charger 100-240Vac / 50-60Hz
- 55/125 lumens
- Operating range: 5 / 2.5 hours
- IP65

018380010

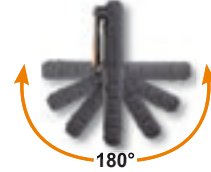

1838SLR



new item

Rechargeable, articulated LED inspection lamp

- Compact front LED (200 lumens) and head LED (100 lumens) for inspections
- Lighting body no more than 9 mm thick
- Operating range: 5/2.5 hours (depending on light level setting)
- With USB charger
- With metal hook and magnet
- IP80



*Ultrathin
Compact
and versatile*

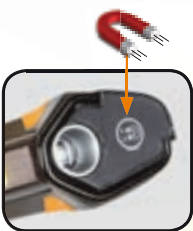

242x41x30mm

018380201



1838FLASH



Rechargeable, ultracompact spotlight, designed to offer the best possible solution for each use

- IP65 - without external power supply
- Dual brightness: 650 / 300 lumens
- Lithium polymer battery 7.4 V 4000 mAh



**ABUNDANT
READY LIGHTING:**

with a maximum lighting capacity of 720 lumens, and running on both battery and cable, it is always ready to use



018380300



1838/11LED

Rechargeable inspection lamp with ultra-high brightness LEDs, lithium polymer battery

- Compact body made of antislip rubber
- With charging station, 110-230Vac
- With multidirectional head LED



<20%

even more compact and brighter

now with head LED

Swinging hook

018380111



1842LED/ABM



Lamp with ultra-high brightness LEDs, 12-24 V; AC-DC

- Compact body made of antislip rubber
- Easy-to-replace front glass
- Swinging hook
- With multi-directional head LED light



018420311



1846LED/BM

Automatic cable reel with LED inspection lamp, 100-240 Vac

- With 230/24 V safety transformer
- Max. 25 W

IP42



IP65

018460301



1848



Automatic cable reel with Schuko type socket

- Max. 1600 W with unwound cable
- Max. 1200 W with wound cable
- Crush-resistant rubber cable H07 - 3x1.5 mm² - 15m

018480015



H07

12V

Available from April

new

Ultracompact drill, 12V

1972/12

Ultracompact, no more than 176 mm in length, ultralightweight, no more than 1.1 kg, with battery, perfectly balanced



Ideal for jobs in small areas

019720012

1,1 kg



Beta 3-YEAR WARRANTY

- Double mechanical speed with steel gears and 18-position clutch
- Torque up to 34 Nm and 1500 rpm (350 rpm in 1st gear), drills diameters up to 10 mm in steel and 20 mm in wood
- Ergonomic nonslip handle
- Front LED

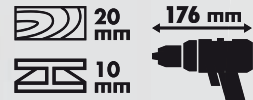

- 2Ah batteries and charge indicator on drill body
- Triple battery self-protection (heat, overload and monitoring of charge differences (if any) between cells) for increased safety and durable high performance
- Supplied in a hard case with 2 lithium ion batteries (2 Ah) and quick charger (45 min)

Reversible impact wrench, 12V

1982/12EF

Ideal for jobs in small areas, provides high torque (115 Nm), one-handed operation



• 0-2.000 rpm / 0-3.000 rpm

019820012

1,1 kg



Beta 3-YEAR WARRANTY

- 1/4" hexagon drive with locknut
- Ultracompact: no more than 163 mm in length; ultralightweight: no more than 1.1 kg, with battery, perfectly balanced
- Ultraleggero: solo 1,1 kg con batteria
- Triple front LED

163 mm



item

**Impact wrench,
18V,
brushless**

**Beta
3-YEAR
WARRANTY**

18V

1984/18QM 1 1/2"

- Triple front LED
- 4 modes available:
1: 270Nm; 1400 RPM
2: 360Nm; 2000 RPM
3: 450Nm; 2750 RPM
A: 450Nm Autostop- As long as the impact wrench detects a free rotation, it applies maximum torque/speed (450Nm; 2750 RPM)
When the nut reaches the end of stroke and stops rotating, the impact wrench keeps applying maximum torque for 1 second; then it sets itself to the lowest level, to avoid damaging the nut.



2,3 kg

019840018

270 Nm
360 Nm
450 Nm
Autostop

BRUSHLESS

Digital brushless motor: remarkably enhanced performance, including: increased power, reduced energy consumption

- 5Ah batteries with charge indicator
- Triple battery self-protection (heat, overload and monitoring of charge differences (if any) between cells) for increased safety and durable high performance
- Supplied in a hard case with 1/4" hexagon bit holder adaptor, 2 lithium ion batteries (5 Ah) and quick charger (80 min)

**Percussion drill,
18 V, brushless
-ultracompact-**

1972/18

2-13 mm

- 13-mm steel chuck with free ring nut on tip, in order not to damage surfaces in case of friction
- Torque up to 75 Nm and 2100 rpm (550 rpm in 1st gear); drills diameters up to 13 mm in steel and 45 mm in wood
- Double mechanical speed with steel gears and selector switch for drilling, percussion drilling and screwing operations, with 20-position clutch
- Front LED
- With side handle for high torque use

**Beta
3-YEAR
WARRANTY**

- Gearcase made entirely from metal, for increased sturdiness and durability



019720018

2,2 kg



Probe Ø 5.5 mm,
with front and side camera,
4 LEDs

961D



Digital electronic videoscope with 5.5 mm probe

Allows individual still images and video clips to be recorded and played back directly on tool

Optimal viewing distance:	2,5-30 cm
Power supply:	3,7V - 4200 mAh
Estimated battery life:	2,5-4 ore
Weight:	520g
Sensor resolution:	640x480 pixels (digitale) IP23S
Viewing width:	60 gradi
Video and photo resolution:	640x480
Dimensions:	184x144x27 mm

009610500



Micro-SD card input



Microphone



Micro USB



Micro HDMI

961D/CF3,8

1-m probe with 3.8-mm front camera

009610511



961D/DC8,5

1-m probe with dual UV camera

009610513



Electronic battery chargers



IP65

- Allow charging and maintenance of all battery types
- Automatic multi-stage charge cycle
- Reverse polarity and short-circuit protection

new item

1498/2A

1498/4A

1498/8A

Power supply voltage:	220V-240V	220V-240V	220V-240V
Frequency:	50-60 Hz	50-60 Hz	50-60 Hz
Rated current (min-max):	1 Amp	1-4 Amp	2-8 Amp
Battery voltage:	12V	6V/12V	12V
Battery capacity:	2Ah-40Ah	4Ah-80Ah	5Ah-160Ah
Degree of protection:	IP65	IP65	IP65
Battery type:	Lithium Wet-Gel Dry-AGM	Wet-Gel Dry-AGM	Wet-Gel Dry-AGM



1498/4A



014980104



1498/2A



014980102



1498/8A



014980108



Automotive

1760PA/AC-DC

Amperometric clamp and digital multimeter

- Allows DC and AC measurements up to 1000 A
- Integrated multimeter function
- A: AC/DC
- V: AC/DC

 017600000



SPECIFICATIONS

- DC voltage: 0.1mV ÷ 600V
- AC voltage: 0.1mV ÷ 600V
- AC current: 0.01A ÷ 1000A
- DC current: 0.01A ÷ 1000A
- Resistance: 0.1Ω ÷ 40MΩ
- Capacity: 0.001nF ÷ 40 μF
- Frequency: 0.001kHz ÷ 4kHz
- Temperature: -40°C ÷ 1000 °C
- 40°F ÷ 1832°F
- Power supply: 1 9V battery (not included)

1498/40A



 Wet, Gel Dry, Agm **IP65**

Multipurpose battery charger starter, 12-24V wheeled

- Specific WET-SPIRAL/GEL-AGM charging cycles
- Electronic control and protection system
- Battery desulfurization and recovery function
- Supply function
- Also suitable for Start&Stop batteries

Power supply:	230V
Output voltage:	12-24V
Charging current:	1-40A
Starting current:	350A max cc
Charging capacity:	4-450Ah

 014980140

*2 in 1
battery charger
+ starter*

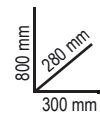

1498TB/12

Digital battery tester, 12V

- Allows the following to be tested: battery, alternator and starter
- 10 language software
- Complete with input for connecting a removable mini printer (optional accessory)

TECHNICAL DATA:

- Operating range: 100-1700 CCA
- Reference standards: CCA,SAE,DIN,EN,IEC,JIS
- Batteries supported: PB, Wet, Gel, Agm, Mf, Vrla, Sli
- Voltmeter: 9V-15V



 370x270x100 mm

 014980400



1498TC

Digital glow plug tester

- Quick, accurate glow plug testing
- Suitable for all types of glow plugs, 4.4-5-7-8.5-10-11 Volts
- With buzzer
- With SMD LED torch
- Measurement range: 0.00÷25.0Ω



 014980450



Weighs no more than 2.5 kg!

1498LT/12



Portable high-performance starter, ultralightweight

Operating voltage	12V
Continuous amperage	800A
Maximum pickup amperage	2000A
Peak amperage	4000A
Cable length	500 mm
Battery type	4-cell LifePo4
Memory saving function	Yes
Dimensions:	260x135x72
Complete with charging power supply	12 V 1,3A

4000A



Includes memory save

014980012

Multipurpose portable starters



3 functions in 1:

- starter
- additional battery for electronic devices (tablets, smartphones etc.)
- high-brightness LED torch

1498CM/12



Portable motorcycle emergency starter



new item

014980030

1498MN/12



Multipurpose portable starter



014980000



1498CM/12 1498MN/12

Peak current:	400A	600A
USB outlet:	5V 2,1A	5V 1A-2A
Dimensions	130x50x15 mm	190x85x35 mm
Weight:	300 g	542 g
Starting output:	12 Volt	12 Volt



Equipment:

- Starting cable with insulated clamps and protection diode
- Mains battery charger
- Car battery charger
- USB cable with charge adapters

240x185x60 mm

Car, commercial vehicle and truck starters

	1498/24	1498C/24
Peak amperage:	4200 A (12 V) 2100 A (24 V)	4000A (24V)
Operating voltage:	12-24 V	24V
Battery type:	AGM	AGM
Cable length:	160 cm	200 cm
Charging voltage:	230V	230V
Weight:	17 kg	50 kg



1498C/24



Pb Wet, Gel Dry, Agm **IP65**

- Wheeled
- Outstanding performance for numerous starts, including particularly demanding ones



1498/24



12V-24V



014980490



24V

950 mm
460 mm
230 mm

014980244



CX49

new item

Multi-purpose trolley, empty can be used as a mobile workstation for diagnostic tools, laptops, testers and battery chargers.

- Painted sheet metal frame: unparalleled firmness and sturdiness
- Ergonomic handle
- 2 fixed rear castors Ø 160 mm
- 2 steering front castors Ø 125 mm (one with brake)

2 central shelves with adjustable position and 1 fixed low shelf

2-level top

Pull-out drawer for housing a mini keyboard



4 useful side cable reels made of plastic



2 useful side containers

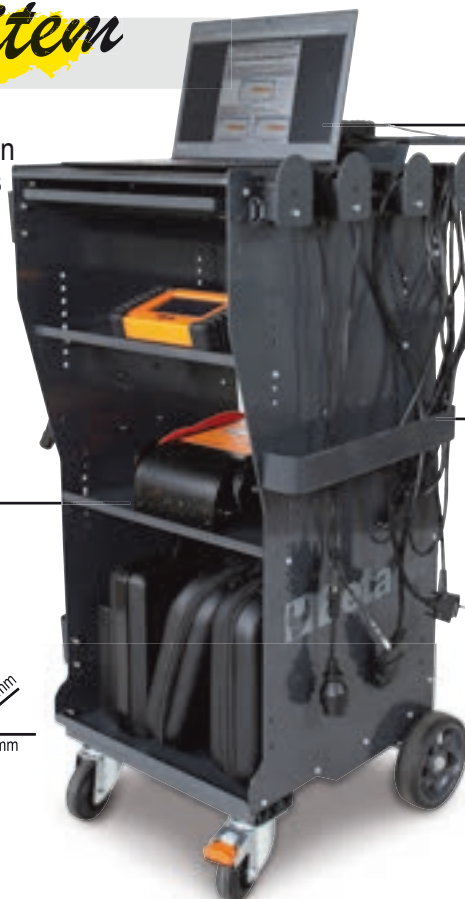

36 kg

1099 mm
460 mm
435 mm

049000102



new item

1464APB

Set for testing high pressure system in FSI petrol engines, for use with item 1464

Comes with 200 bar sensor and connectors

014640500



240x210x50 mm



1464T

Digital pressure and compression tester



014640050

new item

1464TDI

Set for testing pump pressure in TDI engines, for use with item 1464T

Comes with connector

014640600



240x210x50 mm

960AD/TP2

Set of adaptors for item 1464T

- Dummy injectors
- Dummy glow plugs
- Spark plug adaptors
- Oil cap adaptors
- Petrol injection couplers
- Set of spare gaskets



430x310x50 mm

1464AP

Set for testing high pressure system in common rail diesel engines, with item 1464T

- High pressure pipe set
- Fittings
- 2,000 bar sensor

014640450



430x310x50 mm

009600510

New sets for the multi-function tester

SPECIFICATIONS

- 5" touch screen display
- rechargeable polymer lithium battery
- complete with 80 bar sensor (for low pressure) and USB cable



Automotive

1464PT

new item

Set for testing turbo pressure, for use with item 1464T

Comes with sensor and connecting cable

014640550

240x210x50 mm



1464PF

new item

Set for testing pressure in braking system, for use with item 1464T

Comes with adapters and connectors

014640650

600x280x60 mm



1464IC

Set of dummy injectors and dummy glow plugs for item 1464T

Makes it possible to connect to the engine to check compression in diesel engines with digital tester 1464T.

- 22 dummy glow plugs
- 5 dummy injectors
- 1 universal dummy injector kit for trucks, marine engines and agricultural machines

014640350

559x312x50 mm



1759HD/3

Cooling system seal testing and circuit filling tools

- Make it possible to check circuit (pipes, joints, pumps, radiators) for leaks under pressure and quickly fill circuit, avoiding air bubble formation

017590063

600x500x140 mm



1472FCA

new item

Collar removal pliers with Visa® type rack

014720041



Easy block opening, without risk of causing damage

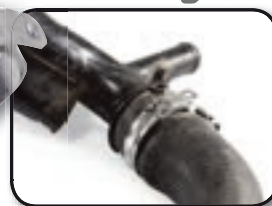

1472H

Simple and quick

Henn clamp removal tool

014720000



new item



1497CEL

new item

Tool for removing electrical connectors from VAG group vehicles

Allows connectors to be quickly disconnected, without getting damaged.

014970170



960KPC **1/4"**

Reversible impulse extractor with adjustable torque for glow plugs

- Pneumatic extractor with adjustable torque and special sockets allow jammed glow plugs to be unscrewed, thereby minimizing damage risk
- 5 1/4" impact sockets, long series, specially designed for glow plugs: 8-9-10-11-12 mm, 2 extensions and 1 articulated joint
- 4 adjustable driving torques: 10-20-30-40 Nm
- Right-hand and left-hand adjustment

009600780



Prevents glow plugs from being broken during disassembly

420x185x60 mm

960KC/M....

Assortment of tools for removing broken or damaged glow plugs

For spark plugs with threads M8-M9-M10

009600801



380x290x50 mm

960EPC

Set of tools for removing glow plug electrode

- Allows end part of electrode to be correctly and quickly removed in case of breaks or seizures in glow plug seat.
- Suitable for glow plugs with threads M8x1 - M9x1 - M10x1 - M10x1,25

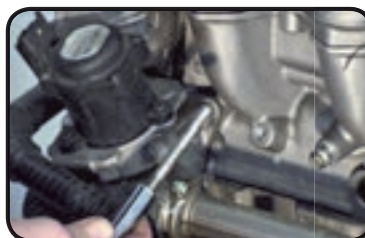

009600790



270x230x80 mm

new item

960UC

Tool set for removing stuck M8-M9-M10 glow plugs with deformed tips

- Allows the glow plug hexagon to be grasped
- Fitted with innovative "fast lock" system which ensures the utmost quickness
- Does not damage the engine head and ensures professional work
- Pulls out glow plugs through the slide hammer supplied with it



Ideal for stuck and deformed glow plugs

275x250x50 mm

009600900



1462KI

Allows removal of DELPHI-BOSCH SIEMENS-DENSO injectors

- Mechanical and hydraulic operation
- Includes one 12-t hydraulic jack
- Can be directly used on vehicle with mounted engine
- Numerous adjustment options on head make it possible to work on most engines available



014620235

590x470x140 mm



960RPI

new item

Blowing tool for injectors seat cleaning

For M8x1 - M9x1 - M10x1 - M10x1.25 glow plugs



- Comes with:
- valve to cut off air through a lever
 - 4 extensions for glow plug seats

009600940

new item

1462CF/C6

12"



Easy access
to fuel connector
locking nut

Automotive

Set of 6 single-ended bi-hex wrenches for fuel injector connectors

Sizes included in set:
12-14-16-17-18-19 mm

014620006

260x145x60 mm

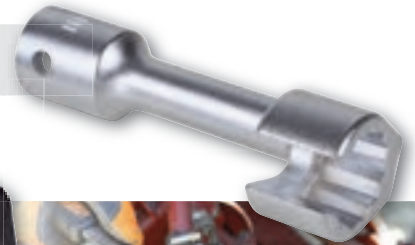

960PI/S

1/4"

Kit for cleaning injector seats

Kit contents:

- 3 steel brushes, Ø 18, 22, 25 mm, for cleaning injector seats
- 2 brushes, Ø 14 and 16 mm, for cleaning injector seat bottoms
- 6 caps for closing hole connecting with combustion chamber
- 1 brush for cleaning hole connecting with combustion chamber
- 1 flexible bit holder with handle

009600214

Flexible accessory
handle suiting all angles



1895 6

new item

Ultrasonic cleaning tank, 6 l

- Ultrasonic cleaning relies on fluid heating to effectively clean spare parts and metal pieces in general (injectors, carburetors, valves etc.)
- Digital display with temperature and cleaning time selection
- For more accurate cleaning, add non-foaming detergent solutions specific for ultrasonic tanks
- Using the degas mode speeds up air release throughout the tank, thereby improving ultrasonic cleaning efficiency.

Ideal
for injectors



Tank capacity	6 l
Heating power:	300 Watt
Temperature range	0+80°C
Cleaning time range	0-99 minutes
Frequency	40 kHz
Power supply:	220/230V

018950060



1485BP

new item

Half-moon tool for locking toothed pulleys

Can be adjusted through swivel handle, tightens and locks pulley from outside, preventing neighbouring sensors from getting damaged

014850000



1485VAG/K2

new item

Tools for pre-loading timing belt bearings, pair

- 3-position swivel head
- 1 tool with 12.5-mm-deep head
- 1 tool with 21.5 mm-deep head

014850080



1485MJ

new item

Camshaft locking tool, for 1.3 16V Multijet engines

2 3-form heads for working on all 1.3 16V Multijet engines of FCA, Opel, Ford and Suzuki group vehicles

014850150



An essential tool for working with timing pins fitted in

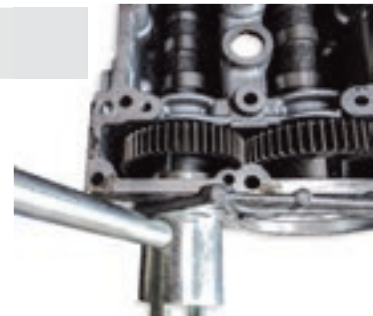

1529/C7

new item

Pulley puller

Kit contents:

- 2 legs with two 4.7-mm-thick feet
- 2 legs with one 4.3-mm-thick foot
- 1 leg with two 2.3-mm-thick feet
- 1 leg with one 2.3-mm-thick foot

The pair of legs can be made up according to one's operating requirements

015290100



285x155x50 mm

new item

1548/C8



Internal gearbox bearing puller for FCA and Opel group vehicles

Comes with 2 pairs of legs and 4 different supports to adjust to different models manufactured since 2007

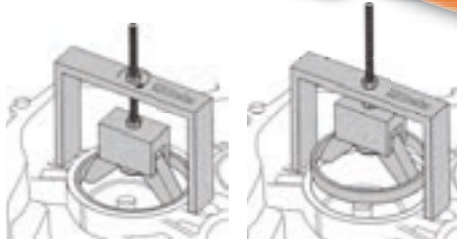

420x180x60 mm

015480800

1884

Oil filler tool for manual and automatic gearboxes and differentials

Complete with 12 adaptors for direct connection

- Fitted with nonreturn valve for leakage-free oil filling
- Delivery: 70 cc per pump shot
- Tank capacity: 7.5 l
- Maximum permissible oil viscosity: SAE 140



12 adaptors

FORD	AT-101
UNIVERSAL (Bmw, Honda, Nissan...)	AT-102
VW-AUDI	AT-103
VW-AUDI-PORSCHE	AT-104
VW-AUDI-MINI COOPER	AT-105
MERCEDES	AT-106
DSG	AT-107
VW-AUDI CVT	AT-108
VOLVO	AT-109
TOYOTA-LEXUS	AT-110
SKODA	AT-111
VW Passat/Tiguan <2007	AT-112

018840010

1493DSG

new item

Wrench for removing/installing DSG oil filter

Allows filter to be reached without having to remove any other parts

014930800



1438DSG

new item



Lever for locking/unlocking DSG dual-clutch gearbox from VAG group

014380200

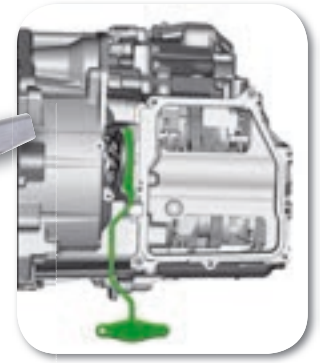

1482

Adjustable self-locking wrench for tank floating ring nuts

014820001



1493FT 12"

new item



Wrench for Ford Transit Diesel oil filters

Can be used for all Transit, Transit Custom and Tourneo Custom versions manufactured since 2012

014930085



1493B/S5 38"

new item

Set of 5 bi-hex wrenches for hard-to-reach oil filter cartridges

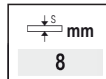

Sizes included in set: 24-27-32-36-38 mm

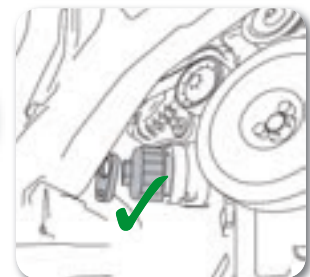
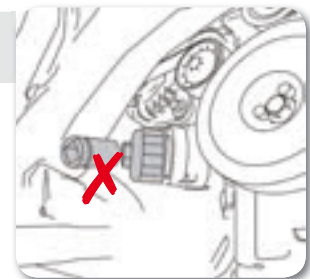
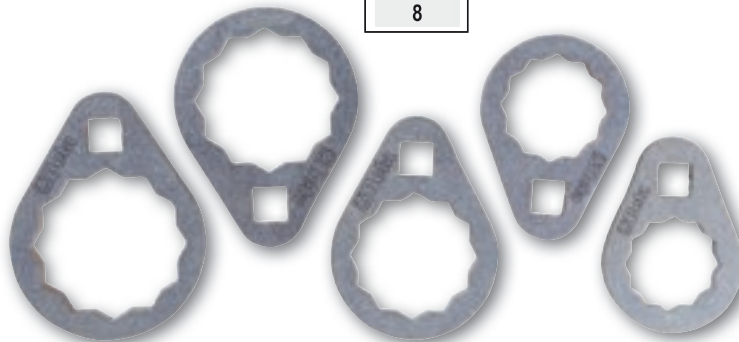

014930599



Oil drain units

Automotive

- level indicator
- big diameter pan with breakwater grate; capacity: 12 l
- pneumatic tank emptying through 1.8 m pipe



1877

Exhausted oil drain unit, wheeled, with 90 l tank

018770008



1877A

Exhausted oil drain unit / vacuum cleaner, wheeled, with 90 l tank and pre-chamber"

- Transparent pre-chamber: capacity 9.5 l
- 1.8-m suction pipe

018770080

1758LG

Multi-use

Formable, rubber-covered aluminium foil, for canalizing liquids

L	H
mm	mm
365	168

017580006

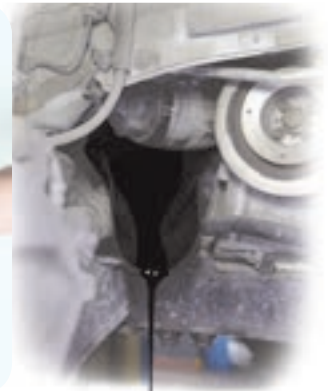
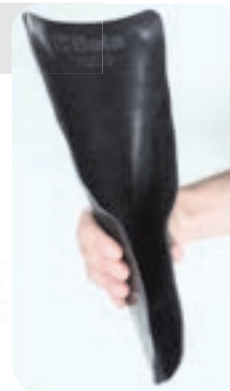

new item

1466/C5



Kit of 5 brake bleeding wrenches

Kit of 5 brake bleeding wrenches

Wrench does not have to be removed to bleed brakes

014660100

Oil goes into bush



260x170x50 mm

1471M/C22

Pneumatic tool for pushing back and rotating right and left disc brake pistons with accessories in plastic case

- Automatic jack
- Thrust: 150 kg
- Operating pressure 5÷8 bar

 014710101

 350x310x85 mm



1569/A

Assortment of tools for removing and installing rear axle silent blocks, driving shaft oil seals and wheel bearings

- Bushings can be used both on vehicle and on hydraulic press
- Direct extraction with wrench
- User-friendly, no pneumatic or hydraulic machines required

- Kit contents: 4 threaded bars: M10-M12-M14-M16
- 4 washers bushings for diameters ranging from 44 mm to 82 mm

 015690011

 530x415x115 mm



1569/B

new item

Assortment of tools for removing and installing silent blocks, oil seals and wheel bearings

- Direct extraction with wrench
- User-friendly, no pneumatic or hydraulic tools required
- Can be used with Beta kit 1569/A

- Kit contents:
- threaded bars, washers and bushings for diameters 14÷32 mm

*Diameter:
14÷32 mm*

 015690015

 530x415x115 mm



Striking tools for installing conical bearings and oil seals Automotive

1569CP/50

A min÷Max 9,5÷50 mm L 130 mm

015690750

1569CP/90

A min÷Max 18÷90 mm L 145 mm

015690790

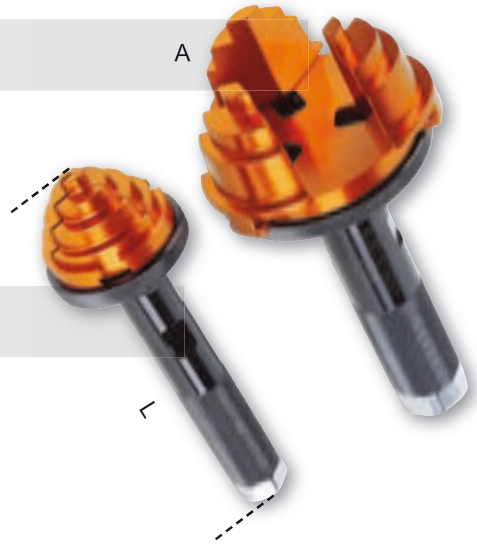

1530/C5

Wheel hub and bearing pulling kit,
3, 4, 5 holes

Kit contents:

- 1 universal flange (96÷138 mm)
- 1 hydraulic screw (12 t)
- 1 hammer face (2.8 kg), required for hubs without central fixing bolts

015300300



1558/C4



new item

Internal and external
snap ring tool, screw-operated

Square drive allows a high force
to be applied in both operating
conditions

015580100



Supplied tips:
Ø 2,5-3-3,5 mm

984

new item

Wheel nut plastic cap pliers

L mm	H mm
195	4



009840005

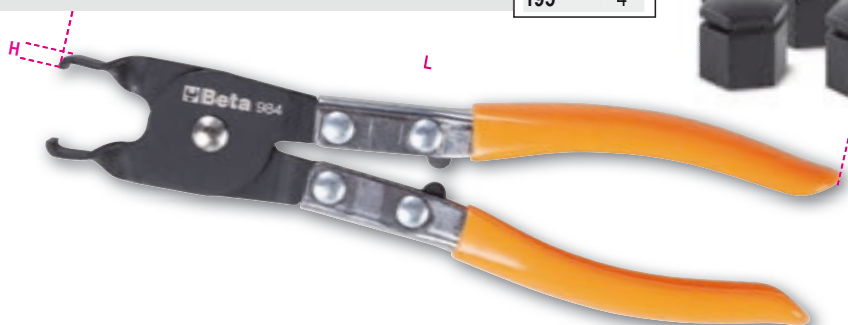

1567

Lever for removing wishbone heads and shock absorbers from pillar

One operator can position lever effortlessly and proceed with disassembly

015670001

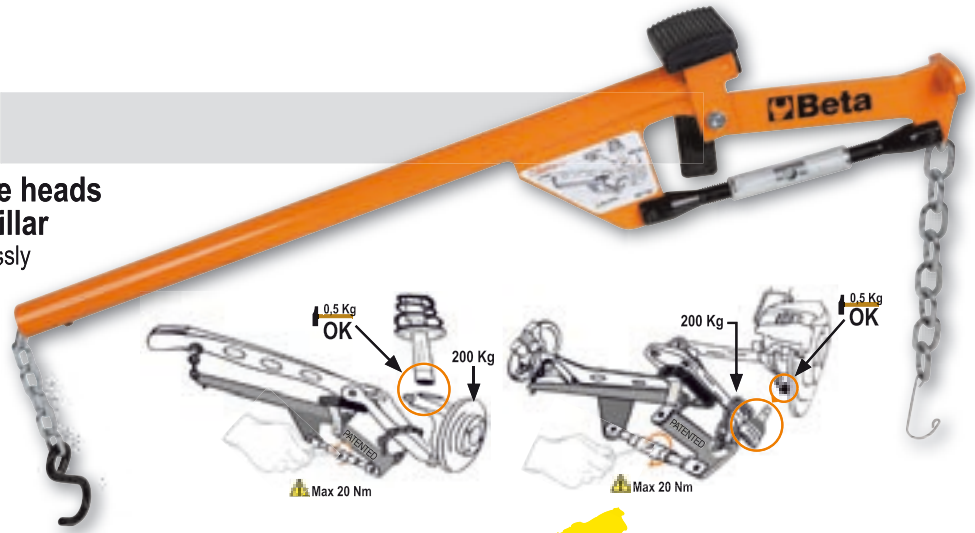

3035

Tyre trolley

- For easily transporting tyres up to 980 mm in diameter
- Can be used as a top by locking position horizontally
- 2 castors Ø 260 mm and 2 castors Ø 125 mm
- Maximum transportable height: 1.60 m
- Maximum carrying capacity: 200 kg
- Forks can be adjusted in 2 positions: 880 mm and 980 mm

030350100



new item

1767A

Telescopic rod

- Designed to support bonnets and tailgates with decompressed pistons.
- Can be used to keep pedals from moving.

L 640 mm ÷ 1090 mm

017670000



720LC/C3

12"



3 impact sockets for wheel nuts, with polymeric inserts

in plastic case

Ø: 17 - 19 - 21 mm

007200653



148x132x44 mm

1550U 

Pneumatic shock absorber removal tool for cars, SUVs and commercial vehicles

UPPER UNIVERSAL HOLD SYSTEM
ACTIVE SAFETY SYSTEM ON SPRING
PROTECTIVE "FULL BODY" GRILLE

Supplied with 2 lower forks for diameters 78-205 mm

TECHNICAL DATA

Maximum thrust: 2 tons (10 bar) - 1.6 tons (8 bar) - 1.2 tons (6 bar)

Spring compression stroke: 335 mm

 015500010

Maximum thrust: 2 tons (10 bar)



1670 mm
610 mm
825 mm

1550U/SS187

Left-hand fork for item 1550U

Particularly suitable for left-hand springs e.g. Nissan Qashqai and Renault Koleos
Diameter 105-187 mm

 015500018



1550U/M

Vice for shock absorber removal tool item 1550U

Allows shock absorber stem to be locked

 015500021



1457/B4

new item

Tool set for releasing Rilsan hose fittings

Sizes included in set:

- 6x8
- 10x12
- 15x16
- 18x1/2



 014570024

1365/K13

Oil pressure pump, 10 t, and bodywork accessories kit in handy trolley

Kit contents:

- Oil pressure pump, 10 t, and piston
- Wing opening pliers and baseplate
- L-shaped base, punches and extensions
- Male-to-male coupling for installing accessories

013650013

900x420x180 mm



1368

Plastic repair kit

- power supply: 220÷240 V with Schuko socket
- heat gun cable length: 3.5 m
- power supply cable length: 1.35 m
- 2 power adjustments: 35-75 W
- heat gun with brass terminals, 2 staple insertion angles: 0°-90°
- input protection: thermal circuit breaker
- output protection: 10 A fuse
- metal gun pocket

013680001



Allows cracked and broken plastic parts to be quickly fixed



1368G/K400

Assortment of 400 clips for item 1368

Supplied with:

- 100 small coil clips
- 100 big coil clips
- 100 clips for concave angles
- 100 clips for convex angles

013680140



1366/K5

Pneumatic dent puller, with 1.1 kg hammer face

Kit contents:

- 1 suction cup Ø 75 mm
- 1 suction cup Ø 100 mm
- 1 suction cup Ø 125 mm
- 1 hook

Heavy duty suction cups

013660010

610x240x90 mm



1360/K6

new item

Useful handle accommodating accessories

Aluminium hammer with flat, round face, interchangeable plastic pins and centre punch

Supplied with:

- 4 plastic pins
- 1 punch, adjustable in 2 different lengths, applicable to hammer

013600006



1366A

new item

Dent puller with kit of 19 plastic glue tabs

To be used with hot glue for painted surfaces

Ideal for removing:

- hail dents
- dents caused by doors
- small dents in general

013660200



1366/KF

Kit of 19 plastic glue tabs for item 1366A

013660205



1478/3P

new item

Plastic pin removal pliers with 3 release points

014780151

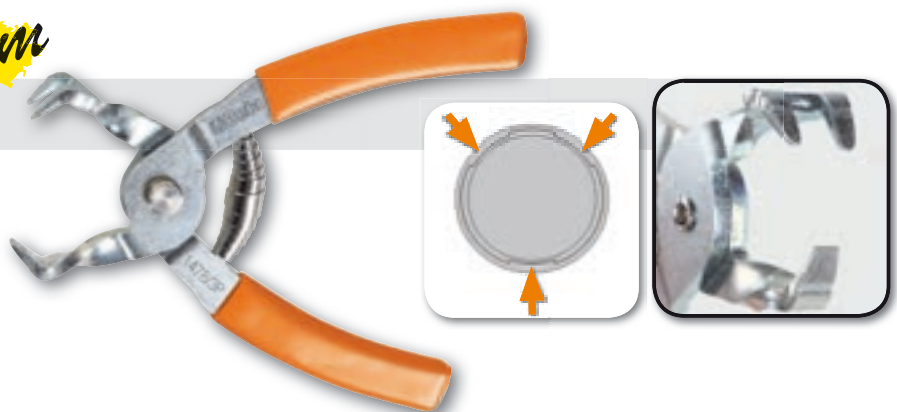

1479L/S2

new item

Multipurpose wrecking bars, pair, made of Teflon®

014790510

Multi-purpose uses



High stress resistance



1344

new item

Feeler gauges for car body repair shops, pair, 10-bladed, with suction cup

013440010

- Suitable for:
- fitting rear windows
 - maintaining position during installation



1362

new item

Dent reflector with suction cup

Allows even the smallest bodywork imperfections to be detected

LxH
mm
240x200

013620010



1367/S6

new item

Set of punches for installing parking sensors

Sizes included in set:
Ø 17 - 18 - 19 - 20 - 21 - 22 mm

*Perpendicular,
burr-free holes*



013670100



1498PC 12-24 V

Protects control units in welding and starting processes

Voltage stabilizer, 12-24 V

014980801

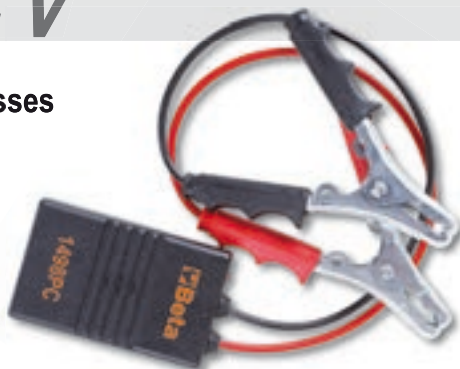

1477/C10

Bent wrench with 9 bits
for belt tightening nuts

1 bent wrench with bit drive
4 double bi-hex bits: 12x14 - 13x15 - 16x17 - 18x19 mm
5 bits for Torx(R) head screws: E10 - E12 - E14 - E16 - E18

014770310



1497/C23

Assortment of 23 tools
for releasing electrical connectors

014970200



1482B

Quick coupler pliers for fuel pipes

014820021



1479/B27

Kit of 27 nylon tools for removing pins
and working on plastics and seals

*Convenient hanging wallet
for viewing all tools*

014790407



3030/2T

Lowered hydraulic car jack, 2 t, with 6 wheels

- Car jack can be easily handled on uneven, irregular floors
- Dual front tilting wheels made of plastic material (PTFE)
- Pedal allows easy approach

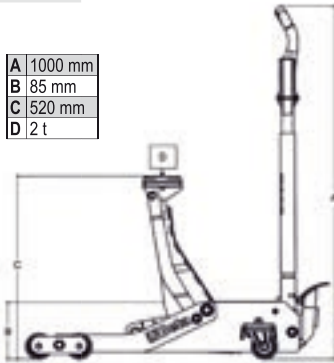

Maximum capacity:	2 t
Minimum plate height	85 - 520 mm
Controlled descent valves:	
weight:	45 kg
indicated for:	

030300020

1493/C30

1/2"

014930000

Set of 28 oil filter wrenches

- For tightening and loosening oil filters
- 1/2" female drive
- In plastic case

Sizes included in kit Ø mm / n° of sides
1493:

65/14 - 67/14 - 68/14 - 73/14 - 74/15
76/15 - 75.77/15 - 76/14 - 76/8 - 78/15
80/15 - 82/15 - 86/16 - 90/15 - 92/10
93/15 - 95/15 - 100/15 - 106/15 - 108/15

1493PF (Purflux)
66/6 - 76/12 - 76/30 - 86/18
93/36 - 93/45 - 96/18 - 108/18

- Includes 1 adjustable oil filter wrench
Ø 65-120 mm



530x400x100 mm

1491

014910001

Adjustable oil filter wrench



Ø mm 65÷110

3010T

Jack stands, pair



	Max kg	H min mm	H Max mm		
3010/T2	2000	280	425	030100002	
3010/T3	3000	285	430	030100003	
3010/T6	6000	400	580	030100006	
3010/T10	10000	471	735	030100010	

2250-0 *New item*

Heavy duty swivel creeper seat with tray

- Round swivel seat
- Height can be adjusted through a gas piston mechanism (410-530 mm)
- 5 pivoting castors

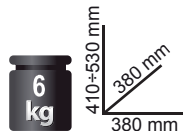

022500011



2 tote/tool trays, one being vertically adjustable

For comfortable working with everything at hand

3000M/LT

Creeper

- PVC lining with upholstered foamed rubber designed for remarkable comfort



Adjustable head-rest by progressive air spring

030000220



3003

Creeper made of shockproof plastic

Ø castors: 76 mm

030030001



120 mm

2254T *New item*

Kneeling pad made from non-slip EVA foam

022540047

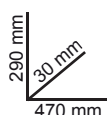



3009

Wheel lifter

Maximum lifting capacity: 550 kg

- 4 pivoting rollers
- Roller width: 200 mm
- For wheels up to 240 mm in width



CASTORS WITH BEARINGS



Ideal for:

- loading damaged cars onto tow trucks
- car repair garages
- moving cars in showrooms

030090001

3007

Underbody trolley for vehicles without forecarriage / rear axle

Allows vehicles without forecarriage or rear axle to be easily handled while working

- 4 pivoting wheels, including 2 with brakes, suitable for use in painting furnaces
- 2 sliding supports to fit all chassis

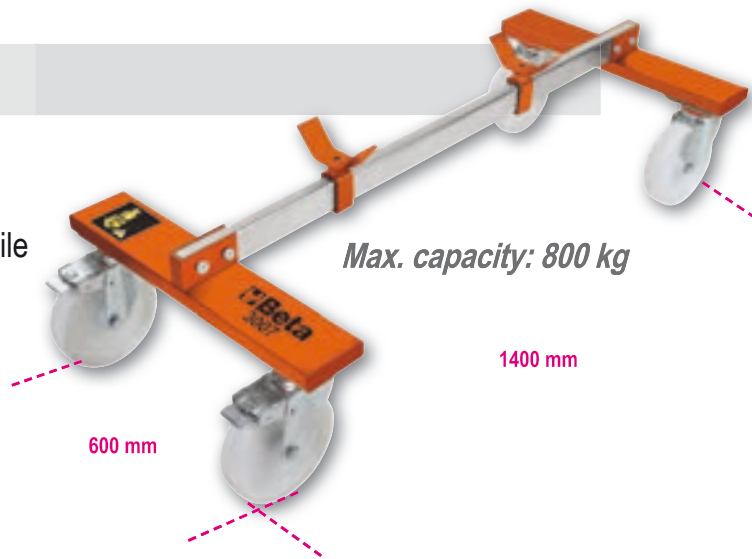

030070001

3025

Folding hydraulic crane with dual effect pump

- Maximum capacity: 1 t
- Folding frame for significantly increased compactness
- With load limiting valve and chrome-plated stand
- Controlled descent speed
- Nylon wheels
- Maximum height: 2400 mm
- Dimensions: 1560 x 1000 mm

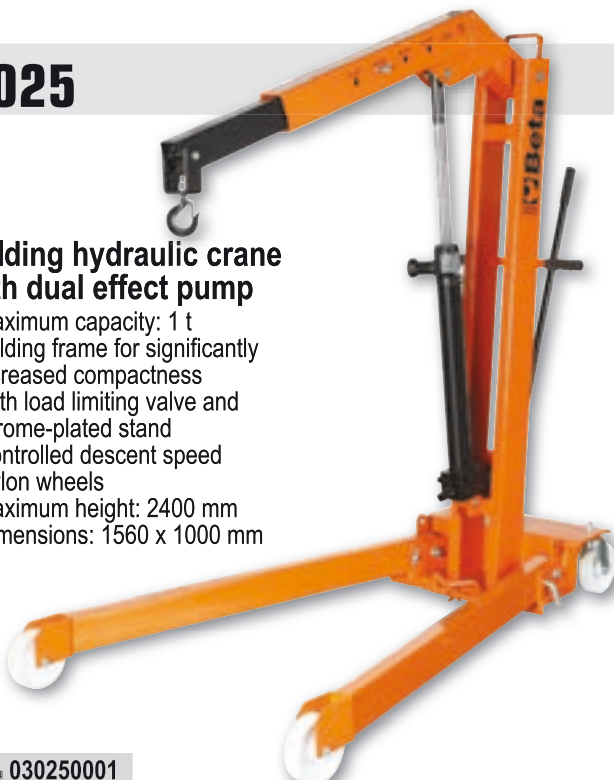

030250001



3025/PF

Barrel handling pliers

70 mm

Maximum capacity: 300 kg



030250011

Pneumatic tools



1927P

Reversible impact wrench, made from composite material

- Lightweight and well-balanced for enhanced ease of use
- Reversible lever
- Three power adjustable screwing positions
- Exhaust through handle
- Vibration-dumping handle

019270008



*Extremely powerful
1750 Nm*

1/2"

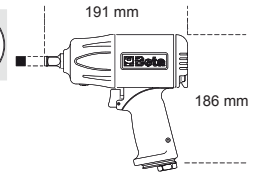

Free speed	rpm	7.500
Impulse device		Double hammer
Maximum torque	Nm	1750
Bolt capacity	Cl 8.8	M24 ● 36 mm
Bolt capacity	Cl 12.9	M20 ● 30 mm
Air inlet	GAS	1/4"
Working pressure	Bar	6,2
Internal hose size (Ø)	mm	10
Mean air consumption	l/min	290
Weight	kg	2



1927XM/K5

Assortment of one compact reversible impact wrench and five impact sockets, in plastic case

- Single hammer impulse device
- Amazingly compact and powerful
- One-hand reverse button
- Three power adjustable screwing/unscrewing positions
- Exhaust through handle
- Balancing hook

720 17-19-21-22-24 mm

019270129

307x206x86 mm



*Ultra compact and powerful
770 Nm*

1/2"

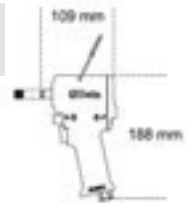

Free speed	rpm	10.000
Impulse device		Single hammer
Max. torque	Nm	770
Bolt capacity	Cl 8.8	M22 ● 34 mm
Bolt capacity	Cl 12.9	M18 ● 27 mm
Air inlet	GAS	1/4"
Operating pressure	bar	6,2
Internal hose size (Ø)	mm	10
Mean air consumption	l/min	122
Weight	kg	1,3



1927CD/K3

Assortment of one reversible impact wrench and three impact sockets

- Double hammer impulse device
- Lightweight and well-balanced for enhanced ease of use
- High torque
- Reversible lever
- Three power adjustable screwing positions
- Exhaust through handle
- Silenced

019270107

350x305x86 mm



720LC 17-19-21 mm

1/2"

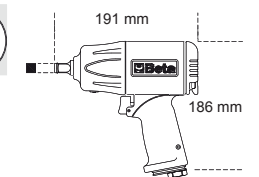

Free speed	rpm	7.000
Impulse device		Double hammer
Maximum torque	Nm	1020
Bolt capacity	Cl 8.8	M22 ● 34 mm
Bolt capacity	Cl 12.9	M18 ● 27 mm
Air inlet	GAS	1/4"
Working pressure	bar	6,2
Internal hose size (Ø)	mm	10
Mean air consumption	l/min	130
Weight	kg	1,9

720S/SB6

1/2"

New item

Set of 6 impact sockets, compact series, 1/2" female drive, with hanging slide

13-15-17-19-22-24 mm

007200906



28 mm



1928K4

Assortment of one reversible impact wrench and four impact sockets, long series

- Extremely powerful in its category
- Reversible lever
- Three power adjustable screwing positions
- Balancing hook

728L 27-30-32-36 mm

019280104

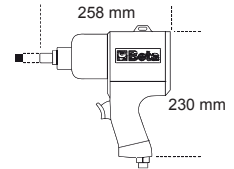

410x330x106 mm

Free speed	rpm	4.000
Impulse device		Pin Clutch
Maximum torque	Nm	1.493
Bolt capacity	CI 8.8	M27●41 mm
Bolt capacity	CI 12.9	M24●36 mm
Air inlet	GAS	3/8"
Working pressure	bar	6,2
Internal hose size (Ø)	mm	10
Mean air consumption	l/min	260
Weight	kg	5,2



1928DA

Reversible impact wrench

- Double hammer impulse device
- Sturdy and compact; high torque
- Reversible lever
- Three power adjustable positions
- Exhaust through handle
- Slip-proof ergonomic handle

019280022

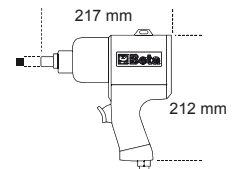

Free speed	rpm	5.000
Impulse device		Double hammer
Max. torque	Nm	1.695
Bolt capacity	CI 8.8	M27●41 mm
Bolt capacity	CI 12.9	M24●36 mm
Air inlet	GAS	3/8"
Working pressure	bar	6,2
Internal hose size (Ø)	mm	10
Mean air consumption	l/min	210
Weight	kg	4,3



1928CD

Reversible impact wrench, made from composite material

- Double hammer impulse device
- High weight/power ratio
- Reversible lever
- Three power adjustable screwing positions
- Exhaust through handle
- Silenced

019280007

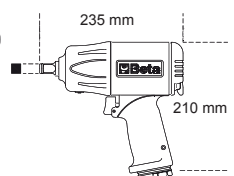

Free speed	rpm	4.500
Impulse device		Double hammer
Maximum torque	Nm	1.800
Bolt capacity	CI 8.8	M27●41 mm
Bolt capacity	CI 12.9	M24●36 mm
Air inlet	GAS	3/8"
Working pressure	bar	6,2
Internal hose size (Ø)	mm	10
Mean air consumption	l/min	215
Weight	kg	3,5

Pneumatic tools



1930PA

1"

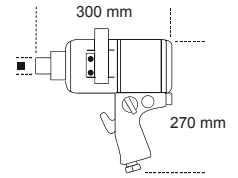

Reversible impact wrench

- Extremely lightweight and compact
- Auxiliary handle
- Reversible lever
- Three power adjustable positions

019300032

Free speed	rpm	3.500
Impulse device		Double hammer
Maximum torque	Nm	2445
Bolt capacity	Cl 8.8	M36●55mm
Bolt capacity	Cl 12.9	M30●46mm
Air inlet	GAS	1/2"
Working pressure	bar	6,2
Internal hose size (Ø)	mm	13
Mean air consumption	l/min	350
Weight	kg	9,6



1930HLA

1"

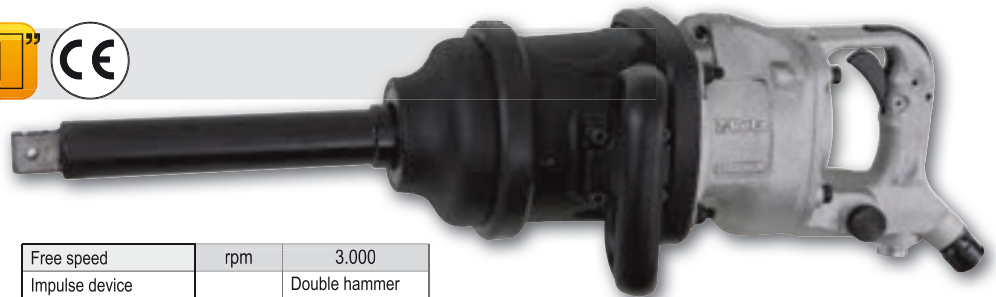

Reversible impact wrench

- Double hammer impulse device
- 9" long anvil
- Auxiliary handle
- Reversible lever
- Three power adjustable screwing positions
- Upper exhaust

019300040

Free speed	rpm	3.000
Impulse device		Double hammer
Maximum torque	Nm	3661
Bolt capacity	Cl 8.8	M42●65mm
Bolt capacity	Cl 12.9	M33●50mm
Air inlet	GAS	1/2"
Working pressure	bar	6,2
Internal hose size (Ø)	mm	13
Mean air consumption	l/min	460
Weight	kg	16,4

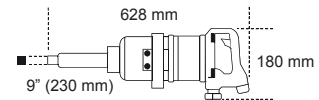

1930ZL

1 1/2"



Reversible impact wrench

- Double hammer impulse device
- Auxiliary handle
- Reversible lever
- Three power adjustable screwing positions
- Upper exhaust

019300070

Free speed	rpm	3.000
Impulse device		Double hammer
Max. torque	Nm	4.068
Bolt capacity	Cl 8.8	M42●65 mm
Bolt capacity	Cl 12.9	M36●55 mm
Air inlet	GAS	1/2"
Working pressure	bar	6,2
Internal hose size (Ø)	mm	13
Mean air consumption	l/min	480
Weight	kg	15

High torque 4068 Nm

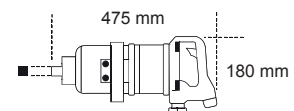

19211

1 1/2"



Impact reversible ratchet

- "Pin Clutch" impulse device
- High Torque (101 Nm)
- Eliminates torque reaction
- Faster than standard ratchets
- Ergonomic rubber handle
- Rear exhaust

019210035

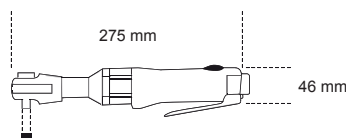

Free speed	rpm	400
Impulse device		Pin Clutch
Max. torque	Nm	101
Bolt capacity	Cl 8.8	M10●16mm
Bolt capacity	Cl 12.9	M8●13mm
Air inlet	GAS	1/4"
Working pressure	bar	6,2
Internal hose size (Ø)	mm	10
Mean air consumption	l/min	235
Weight	kg	1,3

New item

1937RT

Orbital palm sander, made from composite material, with suction system

- Supplied with two sanding pads; rectangular (100x110 mm) and delta-shaped (125x95 mm)
- With Velcro-backed plate
- Extremely compact and easy to handle
- Orbit diameter: 5 mm
- Continuous motor speed adjustment
- Nonslip, soft material handle
- Designed for connection to suction systems with swivel fittings
- Revolving exhaust

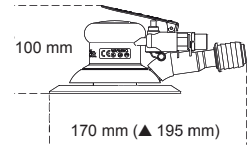

Free speed	rpm	10.000
Air inlet	GAS	1/4"
Operating pressure	bar	6,2
Internal hose size (Ø)	mm	10
Mean air consumption	l/min	180
Weight	kg	0,9

019370021

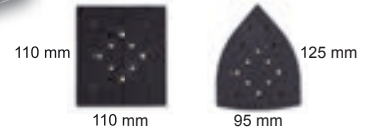

1937

Roto-orbital palm sander, lubrication free, made from composite material

- No lubrication required
- Extremely compact and easy to handle
- Orbit diameter: 5 mm
- 6-hole Velcro pad
- Continuous motor speed adjustment
- Nonslip, soft material handle
- Designed for connection to suction systems with swivel fittings
- Revolving exhaust

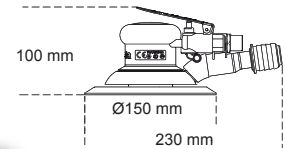

Free speed	rpm	12.000
Power	kW	0,18
Pad size	mm	150
Spindle thread		5/16"-24
Air inlet	GAS	1/4"
Operating pressure	bar	6,2
Internal hose size (Ø)	mm	10
Mean air consumption	l/min	170
Weight	g	860

019370001

1937KC

New item

Mini orbital sander

- Orbit diameter 4 mm
- Supplied with two sanding pads (Ø 50 mm and Ø 75 mm)
- Assortment of 10 abrasive paper discs for each size, grain 400, 600, 800
- Pistol grip
- Power regulator
- Brass capacity regulator
- Suitable for finishing jobs in tight areas



Compact and lightweight: 640 g

280x280x90 mm

019370171

Free speed	rpm	15000
Free speed	kW	0,25
Pad size	mm	50 - 75
Spindle thread		M6 x 1,0
Air inlet	GAS	1/4"
Operating pressure	bar	6,2
Internal hose size (Ø)	mm	10
Mean air consumption	l/min	79
Kit weight	kg	1,4

19331

Die grinder

- Designed for heavy and long duty jobs, was the result of high power
- Slip-proof housing and handle
- Mounted on ball bearings
- Knob speed regulator
- Swivel air inlet
- Silenced rear exhaust
- Safety lever device
- Collect chuck, 3 mm and 6 mm

 019330005

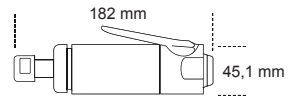

Free speed	rpm	20.000
Chuck capacity	mm	3-6
Power	kW	0,38
Air inlet	GAS	1/4"
Working pressure	bar	6,2
Internal hose size (Ø)	mm	10
Mean air consumption	l/min	260
Weight	g	670

1940E10

Air hammer

- compatible with chisels with 10-mm hexagon drive
- can be used for cutting sheet, bolts and bodies, removing welding slags, rivets, plaster and tiles
- supplied with a spring and a bayonet retainer
- speed control button
- ergonomic, non-slip handle for optimal balance
- exhaust through handle
- shock absorption device

 019400010

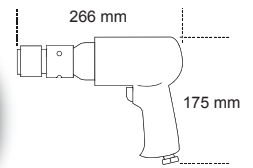

Strokes per minute		2900
Chisel inlet	Ø mm	10
Piston size	mm	19
Piston stroke	mm	67
Air inlet	GAS	1/4"
Operating pressure	bar	6,2
Internal hose size (Ø)	mm	10
Mean air consumption	l/min	76
Weight	kg	1,7

1942A

Air saw

- Powerful and handy
- Designed for cutting bodies, exhaust pipes and silencers, aluminium and plastic
- Complete with rubber handle, PVC exhaust pipe and air-feeding hose
- Rear exhaust

 019420000

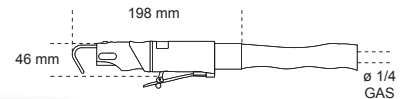

Strokes per minute		10.000
Stroke length	mm	10
Air inlet	GAS	1/4"
Operating pressure	bar	6,2
Internal hose size (Ø)	mm	8
Mean air consumption	l/min	75
Weight	g	550

1949GPE

Tyre inflator

- Operating pressure: 0÷11 bars (0÷160 psi)
- Pressure release feature
- Pressure measurement feature
- Gauge coated with shockproof rubber
- 360 degree hose rotation

 019490008

640
g

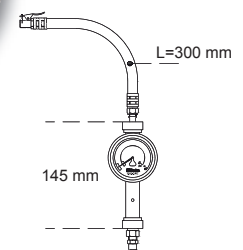

1946C4,8

Automatic air suction riveter

- Professional air riveter for use with 2.4 - 3.2 - 4.0 - 4.8 mm long steel, stainless steel, aluminium and copper rivets
- Pointed cone-shaped spout
- Powerful and handy, with handle made of composite material
- Complete with safety nail container and oil gun

019460006

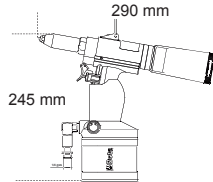

Material/Riveter	2,4	3,2	4	4,8
copper	✓	✓	✓	✓
aluminium	✓	✓	✓	✓
steel	✓	✓	✓	✓
stainless steel	✓	✓	✓	✓

Traction power	N	8.900
Stroke length	mm	15
Maximum rivet capacity	Ø stainless steel	4,8 mm
Air inlet	GAS	1/4"
Working pressure	bar	6,2
Ø interno tubo aria	mm	10
Air consumption	l/cycle	2,6
Weight	kg	1,5

1947G

New item

Grease gun

- Die-cast aluminium head
- Ergonomic grip for ease of access to tough greasing points
- Corrosion-resistant brass valve
- Takes 400 g cartridges or bulk grease up to 500 cc
- Tube size: 54 (interior) x 260 mm
- Air inlet: 1/4" GAS Operating pressure: 4÷10 bar

019470051

Tube size	mm	54x260
Air inlet	GAS	1/4"
Operating pressure	bar	3÷10
Weight	kg	1,16

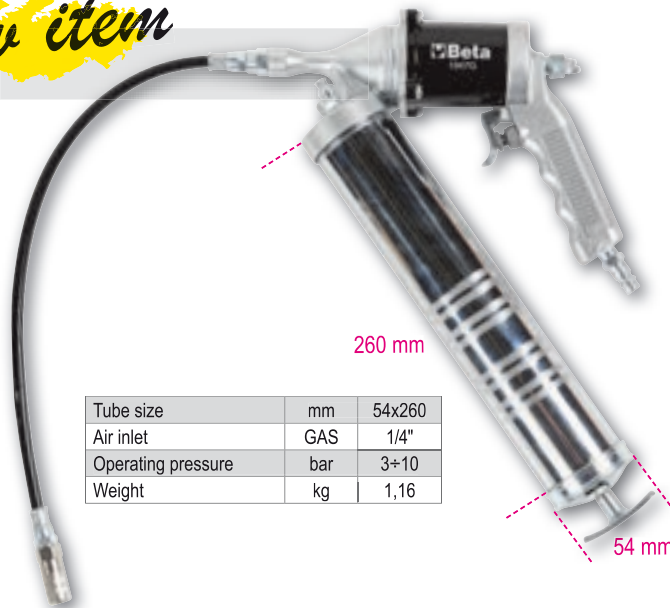

Automatic hose reels

- Shock-proof plastic body for compressed air or cold water
- Metal clamp, revolving
- Device for automatically fixing hose at desired length

1901T/10 1901BM/8

Air inlet	GAS	3/8"	1/4"
Hose length	m	15+1	9+1
Max. operating pressure	bar	15	12
Internal hose size Ø	mm	10	8
Tube material		PVC	polyurethane

1901T/10

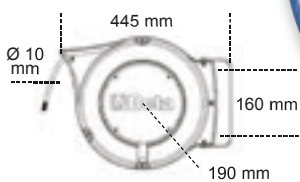

019010210

6,5 kg

1901BM/8

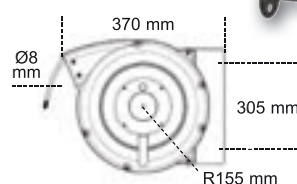

019010111

3,5 kg

Safety footwear

7241C

Leather shoe, waterproof, with penetration proof insole

- Steel toe cap
- Elastic steel penetration proof insole

EU	UK	
35	2,5	072410535
36	3,5	072410536
37	4,5	072410537
38	5	072410538
39	6	072410539
40	6,5	072410540
41	7	072410541
42	8	072410542
43	9	072410543
44	10	072410544
45	10,5	072410545
46	11	072410546
47	12	072410547
48	13	072410548



S3 SRC

7243C

Leather ankle shoe, waterproof, with penetration proof insole and quick opening system

- Steel toe cap
- Elastic steel penetration proof insole

EU	UK	
35	2,5	072430335
36	3,5	072430336
37	4,5	072430337
38	5	072430338
39	6	072430339
40	6,5	072430340
41	7	072430341
42	8	072430342
43	9	072430343
44	10	072430344
45	10,5	072430345
46	11	072430346
47	12	072430347
48	13	072430348



EN ISO 20345 2011



quick opening system

S3 RS SRC

7246B

Suede shoe, perforated

- Steel toe cap
- Elastic steel penetration proof insole

EU	UK	
35	2,5	072460235
36	3,5	072460236
37	4,5	072460237
38	5	072460238
39	6	072460239
40	6,5	072460240
41	7	072460241
42	8	072460242
43	9	072460243
44	10	072460244
45	10,5	072460245
46	11	072460246
47	12	072460247
48	13	072460248



S1P SRC

7245B

Lace-up full-grain leather ankle shoe, waterproof, with quick opening system and front protection with strap closure

- Steel toe cap
- Elastic steel penetration proof insole

EU	UK	
35	2,5	072450235
36	3,5	072450236
37	4,5	072450237
38	5	072450238
39	6	072450239
40	6,5	072450240
41	7	072450241
42	8	072450242
43	9	072450243
44	10	072450244
45	10,5	072450245
46	11	072450246
47	12	072450247
48	13	072450248



EN ISO 20345 2011



quick opening system

S3 RS SRC

7248G

Suede shoe with mesh inserts

- Steel toe cap
- Elastic steel penetration proof insole

EU	UK	
35	2,5	072480135
36	3,5	072480136
37	4,5	072480137
38	5	072480138
39	6	072480139
40	6,5	072480140
41	7	072480141
42	8	072480142
43	9	072480143
44	10	072480144
45	10,5	072480145
46	11	072480146
47	12	072480147
48	13	072480148



EN ISO 20345 2011

S1P SRC

7249G

Suede ankle shoe with mesh inserts

- Steel toe cap
- Elastic steel penetration proof insole

EU	UK	
35	2,5	072490135
36	3,5	072490136
37	4,5	072490137
38	5	072490138
39	6	072490139
40	6,5	072490140
41	7	072490141
42	8	072490142
43	9	072490143
44	10	072490144
45	10,5	072490145
46	11	072490146
47	12	072490147
48	13	072490148



New item

7237WR

Suede ankle shoe with nylon inserts, durable rubber outsole and quick opening system WR (water-resistant) footwear

- Composite toe cap
- Composite fibre penetration-proof insole

EU	UK	
35	2,5	072370235
36	3,5	072370236
37	4,5	072370237
38	5	072370238
39	6	072370239
40	6,5	072370240
41	7	072370241
42	8	072370242
43	9	072370243
44	10	072370244
45	10,5	072370245
46	11	072370246
47	12	072370247
48	13	072370248

7235B

Action Nubuck shoe, waterproof, with nylon inserts

- Steel toe cap
- Elastic steel penetration proof insole

EU	UK	
35	2,5	072350235
36	3,5	072350236
37	4,5	072350237
38	5	072350238
39	6	072350239
40	6,5	072350240
41	7	072350241
42	8	072350242
43	9	072350243
44	10	072350244
45	10,5	072350245
46	11	072350246
47	12	072350247
48	13	072350248



EN ISO 20345 2011

S3 SRC

Endurance

quick opening system



WR



EN ISO 20345 2011

S3 RS WR HRO SRC

7200BKK

Full-grain leather shoe, waterproof

- Composite toe cap
- Composite fibre penetration proof insole

EU	UK	
35	2,5	072000235
36	3,5	072000236
37	4,5	072000237
38	5	072000238
39	6	072000239
40	6,5	072000240
41	7	072000241
42	8	072000242
43	9	072000243
44	10	072000244
45	10,5	072000245
46	11	072000246
47	12	072000247
48	13	072000248



**EN ISO
20345
2011**

S3 SRC

7201BKK

Full-grain leather ankle shoe, waterproof

- Composite toe cap
- Composite fibre penetration proof insole

EU	UK	
35	2,5	072010435
36	3,5	072010436
37	4,5	072010437
38	5	072010438
39	6	072010439
40	6,5	072010440
41	7	072010441
42	8	072010442
43	9	072010443
44	10	072010444
45	10,5	072010445
46	11	072010446
47	12	072010447
48	13	072010448



**EN ISO
20345
2011**

S3 SRC

7210BKK

Soft suede shoe, perforated

- Composite toe cap
- Composite fibre penetration proof insole

EU	UK	
35	2,5	072100335
36	3,5	072100336
37	4,5	072100337
38	5	072100338
39	6	072100339
40	6,5	072100340
41	7	072100341
42	8	072100342
43	9	072100343
44	10	072100344
45	10,5	072100345
46	11	072100346
47	12	072100347
48	13	072100348



**EN ISO
20345
2011**

S1P SRC

7211PG

Suede shoe, perforated

- Composite toe cap
- Composite fibre penetration proof insole

EU	UK	
35	2,5	072110435
36	3,5	072110436
37	4,5	072110437
38	5	072110438
39	6	072110439
40	6,5	072110440
41	7	072110441
42	8	072110442
43	9	072110443
44	10	072110444
45	10,5	072110445
46	11	072110446
47	12	072110447
48	13	072110448



**EN ISO
20345
2011**

S1P SRC



Mugello

Extremely flexible and lightweight
(approximate weight, size 42: 450 g)

New item FLEX

7212FG

EU	UK	
35	2,5	072120035
36	3,5	072120036
37	4,5	072120037
38	5	072120038
39	6	072120039
40	6,5	072120040
41	7	072120041
42	8	072120042
43	9	072120043
44	10	072120044
45	10,5	072120045
46	11	072120046
47	12	072120047
48	13	072120048

Suede shoe, perforated, with anti-abrasion insert in toe cap area

- Composite toe cap
- Composite fibre penetration-proof insole



EN ISO 20345 2011

S1P SRC

7213FG

EU	UK	
35	2,5	072130035
36	3,5	072130036
37	4,5	072130037
38	5	072130038
39	6	072130039
40	6,5	072130040
41	7	072130041
42	8	072130042
43	9	072130043
44	10	072130044
45	10,5	072130045
46	11	072130046
47	12	072130047
48	13	072130048

Suede shoe with highly breathable mesh inserts

- Composite toe cap
- Composite fibre penetration-proof insole



EN ISO 20345 2011

S1P SRC

7214FN

EU	UK	
35	2,5	072140035
36	3,5	072140036
37	4,5	072140037
38	5	072140038
39	6	072140039
40	6,5	072140040
41	7	072140041
42	8	072140042
43	9	072140043
44	10	072140044
45	10,5	072140045
46	11	072140046
47	12	072140047
48	13	072140048

Action nubuck shoe, waterproof, with anti-abrasion insert in toe cap area

- Composite toe cap
- Composite fibre penetration-proof insole



EN ISO 20345 2011

S3 SRC

7216SN

EU	UK	
35	2,5	072160435
36	3,5	072160436
37	4,5	072160437
38	5	072160438
39	6	072160439
40	6,5	072160440
41	7	072160441
42	8	072160442
43	9	072160443
44	10	072160444
45	10,5	072160445
46	11	072160446
47	12	072160447
48	13	072160448

Suede sandal, perforated, with strap closure

- Composite toe cap
- Composite fibre penetration proof insole



EN ISO 20345 2011

S1P SRC

SUZUKA

Safety footwear

7200PN

Full-grain leather shoe, waterproof, with waterproof suede inserts

- Composite toe cap
- Composite fibre penetration proof insole

EU	UK	
35	2,5	072000535
36	3,5	072000536
37	4,5	072000537
38	5	072000538
39	6	072000539
40	6,5	072000540
41	7	072000541
42	8	072000542
43	9	072000543
44	10	072000544
45	10,5	072000545
46	11	072000546
47	12	072000547
48	13	072000548



EN ISO 20345 2011

S3 SRC

7201PN

Full-grain leather ankle shoe, waterproof, with waterproof suede inserts
Quick double-clip opening system

- Composite toe cap
- Composite fibre penetration proof insole

EU	UK	
35	2,5	072010535
36	3,5	072010536
37	4,5	072010537
38	5	072010538
39	6	072010539
40	6,5	072010540
41	7	072010541
42	8	072010542
43	9	072010543
44	10	072010544
45	10,5	072010545
46	11	072010546
47	12	072010547
48	13	072010548



quick opening system



EN ISO 20345 2011

S3 RS SRC

Imola

7316N

Suede shoe, waterproof, with microfibre insert

- Fibreglass toe cap
- Composite fibre penetration proof insole

EU	UK	
35	2,5	073160535
36	3,5	073160536
37	4,5	073160537
38	5	073160538
39	6	073160539
40	6,5	073160540
41	7	073160541
42	8	073160542
43	9	073160543
44	10	073160544
45	10,5	073160545
46	11	073160546
47	12	073160547
48	13	073160548



EN ISO 20345 2011

S3 SRC

Assen

7361UB

Suede shoe, perforated, with canvas inserts, breathable

- Composite toe cap
- Composite fibre penetration-proof insole

EU	UK	
35	2,5	073610235
36	3,5	073610236
37	4,5	073610237
38	5	073610238
39	6	073610239
40	6,5	073610240
41	7	073610241
42	8	073610242
43	9	073610243
44	10	073610244
45	10,5	073610245
46	11	073610246
47	12	073610247
48	13	073610248



EN ISO 20345 2011

S1P SRC

Kyalami

7360UN

Suede shoe, waterproof

- Composite toe cap
- Composite fibre penetration-proof insole

EN ISO 20345 2011

S3 SRC Pergusa



EU	UK	
35	2,5	073600335
36	3,5	073600336
37	4,5	073600337
38	5	073600338
39	6	073600339
40	6,5	073600340
41	7	073600341
42	8	073600342
43	9	073600343
44	10	073600344
45	10,5	073600345
46	11	073600346
47	12	073600347
48	13	073600348

7368UG

Suede ankle shoe, waterproof, soft fabric collar with protective malleolar padding

- Composite toe cap
- Composite fibre penetration-proof insole

EU	UK	
35	2,5	073680435
36	3,5	073680436
37	4,5	073680437
38	5	073680438
39	6	073680439
40	6,5	073680440
41	7	073680441
42	8	073680442
43	9	073680443
44	10	073680444
45	10,5	073680445
46	11	073680446
47	12	073680447
48	13	073680448



EN ISO 20345 2011

S3 SRC

Monaco

7368UN

Suede ankle shoe, waterproof, soft fabric collar with protective malleolar padding

- Composite toe cap
- Composite fibre penetration-proof insole

EU	UK	
35	2,5	073680335
36	3,5	073680336
37	4,5	073680337
38	5	073680338
39	6	073680339
40	6,5	073680340
41	7	073680341
42	8	073680342
43	9	073680343
44	10	073680344
45	10,5	073680345
46	11	073680346
47	12	073680347
48	13	073680348



7250NKK

Suede shoe, waterproof, with microfibre inserts

- Composite toe cap
- Composite fibre penetration proof insole

EU	UK	
38	5	072500238
39	6	072500239
40	6,5	072500240
41	7	072500241
42	8	072500242
43	9	072500243
44	10	072500244
45	10,5	072500245
46	11	072500246
47	12	072500247



EN ISO 20345 2011

S1P SRC

Sepang

7251NKK

Suede ankle shoe, waterproof, with microfibre inserts

- Composite toe cap
- Composite fibre penetration proof insole

EU	UK	
38	5	072510238
39	6	072510239
40	6,5	072510240
41	7	072510241
42	8	072510242
43	9	072510243
44	10	072510244
45	10,5	072510245
46	11	072510246
47	12	072510247



Safety footwear

7340B

Mesh fabric shoe, highly breathable, with high-frequency PU inserts and protective toe cap reinforcement made of crust suede

- Aluminium toe cap
- Composite fibre penetration-proof insole
- FixLock closing makes it easier to put and remove the shoe (traditional laces included)

EU	UK	
36	3,5	073400236
37	4,5	073400237
38	5	073400238
39	6	073400239
40	6,5	073400240
41	7	073400241
42	8	073400242
43	9	073400243
44	10	073400244
45	10,5	073400245
46	11	073400246
47	12	073400247

FIT PRO NET 



EN ISO
20345
2011
S1P SRC

7340Y

Mesh fabric shoe, highly breathable, with high-frequency PU inserts and protective toe cap reinforcement made of crust suede

- Aluminium toe cap
- Composite fibre penetration-proof insole
- FixLock closing makes it easier to put and remove the shoe (traditional laces included)

EU	UK	
36	3,5	073400336
37	4,5	073400337
38	5	073400338
39	6	073400339
40	6,5	073400340
41	7	073400341
42	8	073400342
43	9	073400343
44	10	073400344
45	10,5	073400345
46	11	073400346
47	12	073400347

FIT PRO NET 



New item

7340R

Mesh fabric shoe, highly breathable, with high-frequency PU inserts and protective toe cap reinforcement made of crust suede.

- Aluminium toe cap
- Composite fibre penetration-proof insole
- FixLock closing makes it easier to put and remove the shoe (traditional laces included)

EU	UK	
36	3,5	073400436
37	4,5	073400437
38	5	073400438
39	6	073400439
40	6,5	073400440
41	7	073400441
42	8	073400442
43	9	073400443
44	10	073400444
45	10,5	073400445
46	11	073400446
47	12	073400447

FIT PRO NET 



EN ISO
20345
2011
S1P SRC

7341N

Microsuede shoe, waterproof, with high-frequency PU inserts and protective toe cap reinforcement made of crust suede

- Aluminium toe cap
- Composite fibre penetration-proof insole
- FixLock closing makes it easier to put and remove the shoe (traditional laces included)

EU	UK	
36	3,5	073410236
37	4,5	073410237
38	5	073410238
39	6	073410239
40	6,5	073410240
41	7	073410241
42	8	073410242
43	9	073410243
44	10	073410244
45	10,5	073410245
46	11	073410246
47	12	073410247

FIT PRO 



EN ISO
20345
2011
S3 SRC

New item

7290NA

Full-grain leather, shoe, waterproof, with reinforcement polyurethane toe cap cover and PU/TPU VIBRAM® outsole. ESD

- Composite toe cap
- Composite fibre penetration-proof insole

EU	UK	
36	3,5	072900336
37	4,5	072900337
38	5	072900338
39	6	072900339
40	6,5	072900340
41	7	072900341
42	8	072900342
43	9	072900343
44	10	072900344
45	10,5	072900345
46	11	072900346
47	12	072900347
48	13	072900348



S3 SRC ESD
Speed

New item

7291NA

Full-grain leather ankle shoe, waterproof, with reinforcement polyurethane toe cap cover and PU/TPU VIBRAM® outsole. ESD

- Composite toe cap
- Composite fibre penetration-proof insole

EU	UK	
36	3,5	072910336
37	4,5	072910337
38	5	072910338
39	6	072910339
40	6,5	072910340
41	7	072910341
42	8	072910342
43	9	072910343
44	10	072910344
45	10,5	072910345
46	11	072910346
47	12	072910347
48	13	072910348



S3 SRC ESD
Speed

7293NKK

Greased Nubuck shoe, with dynamic control system and durable VIBRAM® rubber outsole

- Composite toe cap
- Composite fibre penetration proof insole

EU	UK	
38	5	072930138
39	6	072930139
40	6,5	072930140
41	7	072930141
42	8	072930142
43	9	072930143
44	10	072930144
45	10,5	072930145
46	11	072930146
47	12	072930147
48	13	072930148



S3 HRO SRC

7294NKK

Greased Nubuck ankle shoe, with dynamic control system and durable VIBRAM® rubber outsole

- Composite toe cap
- Composite fibre penetration proof insole

EU	UK	
38	5	072940138
39	6	072940139
40	6,5	072940140
41	7	072940141
42	8	072940142
43	9	072940143
44	10	072940144
45	10,5	072940145
46	11	072940146
47	12	072940147
48	13	072940148



Safety footwear

7816G

Work trousers, multipocket style

- T/C canvas, 65% polyester, 35% cotton, 260 g/m²
- Knee pad pockets and leg bottoms reinforced in polyester 600D



XS	078160000
S	078160001
M	078160002
L	078160003
XL	078160004
XXL	078160005
XXXL	078160006



7816BL

Work trousers, multipocket style

- T/C canvas, 65% polyester, 35% cotton, 260 g/m²
- Knee pad pockets and leg bottoms reinforced in polyester 600D



XS	078160100
S	078160101
M	078160102
L	078160103
XL	078160104
XXL	078160105
XXXL	078160106

- Higher waist in rear part for increased back protection
- Stretch rear insert for easier movements
- Stretch waistband on sides
- Two rear pockets with press-stud closure
- Waist key ring
- Large side pockets with press-stud closure, one with badge insert
- Tearproof crotch

New item

SLIM FIT

7880SC

Stretch work trousers Slim fit

- T/C canvas, 290 g/m², black Slim fit, tearproof crotch and stretch waistband on sides

XS	078800000
S	078800001
M	078800002
L	078800003
XL	078800004
XXL	078800005
XXXL	078800006



7840BL

Work trousers

- T/C twill, 245 g/m², blue Stretch waistband on sides

XS	078400100
S	078400101
M	078400102
L	078400103
XL	078400104
XXL	078400105
XXXL	078400106
XXXXL	078400107



- Stretch waistband on sides
- Two large front pockets, one with small pocket
- Two rear pockets with strap closure
- Large left-side pocket with strap closure and badge insert
- Ruler pocket and hammer loop
- Knee pad inserts

STRETCH

SLIM FIT

7830ST

Stretch work trousers,
• T/C twill, 250 g/m², grey

XS	078300000
S	078300001
M	078300002
L	078300003
XL	078300004
XXL	078300005
XXXL	078300006



New item

7831ST

Stretch work Bermuda shorts,
• T/C twill, 250 g/m², grey

- Slim fit
- Tearproof crotch
- Stretch waistband on sides
- Two large front pockets, one with small pocket
- Two rear pockets with strap closure
- Large left-side pocket with strap closure and badge insert
- Ruler pocket and hammer loop
- Knee pad inserts



XS	078310000
S	078310001
M	078310002
L	078310003
XL	078310004
XXL	078310005
XXXL	078310006

New item

7835ST

Stretch work overalls Slim fit

- T/C twill, 63% polyester, 34% cotton, 3% stretch fabric, 250 g/m²
- Front closure with double tab zip and strap closure flap
- Cuffs with strap adjusters
- Left-side chest pocket with strap closure and insert badge
- Right-side chest pocket with strap closure and pen inserts

XS	078350000
S	078350001
M	078350002
L	078350003
XL	078350004
XXL	078350005
XXXL	078350006



New item

7833ST

Stretch work overalls Slim fit

- T/C twill, 250 g/m², grey Slim fit, tearproof crotch and stretch waistband

- Slim fit
- Tearproof crotch
- Stretch waistband
- Two large front pockets, one with small pocket
- Large left-side pocket with strap closure
- Ruler pocket and hammer loop
- Knee pad inserts

XS	078330000
S	078330001
M	078330002
L	078330003
XL	078330004
XXL	078330005
XXXL	078330006



7905E

Work overalls

- Made of T/C canvas, 65% polyester, 35% cotton, 260 g/m²



XS	079050900
S	079050901
M	079050902
L	079050903
XL	079050904
XXL	079050905
XXXL	079050906
XXXXL	079050907



7900E

Work trousers, multipocket style

- Made of T/C canvas, 65% polyester, 35% cotton, 260 g/m²

XS	079000900
S	079000901
M	079000902
L	079000903
XL	079000904
XXL	079000905
XXXL	079000906
XXXXL	079000907



7903E

Work overalls

- Made of T/C canvas, 65% polyester, 35% cotton, 260 g/m²

XS	079030900
S	079030901
M	079030902
L	079030903
XL	079030904
XXL	079030905
XXXL	079030906
XXXXL	079030907



7901E

Work shorts

- Made of T/C canvas, 65% polyester, 35% cotton, 260 g/m²

XS	079010900
S	079010901
M	079010902
L	079010903
XL	079010904
XXL	079010905
XXXL	079010906
XXXXL	079010907



7907E

Sleeveless work jacket, multipocket style

- Made of T/C canvas, 65% polyester, 35% cotton, 260 g/m²

XS	079070900
S	079070901
M	079070902
L	079070903
XL	079070904
XXL	079070905
XXXL	079070906
XXXXL	079070907



7909E

Work jacket

- Made of T/C canvas, 65% polyester, 35% cotton, 260 g/m²

XS	079090900
S	079090901
M	079090902
L	079090903
XL	079090904
XXL	079090905
XXXL	079090906
XXXXL	079090907



7865E

Work overalls, lightweight

- T/C twill, 65% polyester, 35% cotton, 180 g/m²



XS	078650900
S	078650901
M	078650902
L	078650903
XL	078650904
XXL	078650905
XXXL	078650906
XXXXL	078650907



7860E

Work trousers, lightweight

- T/C twill, 65% polyester, 35% cotton, 180 g/m²

XS	078600900
S	078600901
M	078600902
L	078600903
XL	078600904
XXL	078600905
XXXL	078600906
XXXXL	078600907



7863E

Work overalls, lightweight

- T/C twill, 65% polyester, 35% cotton, 180 g/m²

XS	078630900
S	078630901
M	078630902
L	078630903
XL	078630904
XXL	078630905
XXXL	078630906
XXXXL	078630907



7861E

Work Bermuda shorts, lightweight

- T/C twill, 65% polyester, 35% cotton, 180 g/m²

XS	078610900
S	078610901
M	078610902
L	078610903
XL	078610904
XXL	078610905
XXXL	078610906
XXXXL	078610907



7867E

Sleeveless work jacket, multipocket style, lightweight

- T/C twill, 65% polyester, 35% cotton, 180 g/m²

XS	078670900
S	078670901
M	078670902
L	078670903
XL	078670904
XXL	078670905
XXXL	078670906
XXXXL	078670907



7869E

Work jacket, lightweight

- T/C twill, 65% polyester, 35% cotton, 180 g/m²

XS	078690900
S	078690901
M	078690902
L	078690903
XL	078690904
XXL	078690905
XXXL	078690906
XXXXL	078690907



7875E

Work overalls, lightweight

- T/C twill, 65% polyester, 35% cotton, 180 g/m²



XS	078750900
S	078750901
M	078750902
L	078750903
XL	078750904
XXL	078750905
XXXL	078750906
XXXXL	078750907

7870E

Work trousers, lightweight

- T/C twill, 65% polyester, 35% cotton, 180 g/m²



XS	078700900
S	078700901
M	078700902
L	078700903
XL	078700904
XXL	078700905
XXXL	078700906
XXXXL	078700907

7873E

Work overalls, lightweight

- T/C twill, 65% polyester, 35% cotton, 180 g/m²



XS	078730900
S	078730901
M	078730902
L	078730903
XL	078730904
XXL	078730905
XXXL	078730906
XXXXL	078730907

7871E

Work Bermuda shorts, lightweight

- T/C twill, 65% polyester, 35% cotton, 180 g/m²



XS	078710900
S	078710901
M	078710902
L	078710903
XL	078710904
XXL	078710905
XXXL	078710906
XXXXL	078710907

7877E

Sleeveless work jacket, multipocket style, lightweight

- T/C twill, 65% polyester, 35% cotton, 180 g/m²



XS	078770900
S	078770901
M	078770902
L	078770903
XL	078770904
XXL	078770905
XXXL	078770906
XXXXL	078770907

7879E

Work jacket, lightweight

- T/C twill, 65% polyester, 35% cotton, 180 g/m²



XS	078790900
S	078790901
M	078790902
L	078790903
XL	078790904
XXL	078790905
XXXL	078790906
XXXXL	078790907

9563P

095630010

Office armchair, black



9534B

Three-button polo shirt, carded pique cotton 200 g/m², blue

S	095340051
M	095340052
L	095340053
XL	095340054
XXL	095340055



9580S

095800100

Summer sun glasses



9572MB

Beta-March F1 vintage t-shirt, 100% cotton

S	095720701
M	095720702
L	095720703
XL	095720704
XXL	095720705



9541BIKE

095410021

Rucksack made of Oxford polyester, dimensions 41x24x16 cm



9525C

095250051

Ottoman cap, 100% breathable polyester, black, one-size-fits-all adjustable buckle strap



95740

Work gloves

M	095740202
L	095740203
XL	095740204
XXL	095740205



9593B

095930130

Analogue watch, soft touch plastic case, with metal ring, 3 ATM water resistant, silicone strap





SPEEDUP
Racing Spirit



50
years in
motorsports

 **Beta**

www.beta-tools.com



*Beta Utensili S.p.A.
Via Volta 18
20845 Sovico (MB)
Tel.039.2077.1
Fax 039.2010742
www.beta-tools.com*

Promotion valid until 15/12/2018 subject to availability

The images are for reference only. Beta Utensili S.p.A. reserves the right to update and upgrade its product range without notice.